



## **INVITATION TO BID**

**AIR TRAFFIC AND NAVIGATION SERVICES SOC LTD  
REPUBLIC OF SOUTH AFRICA**



**REQUEST FOR PROPOSAL: ATNS/OT/RFP041/23.24/DATA LINKS**

**APPOINTMENT OF A SERVICE PROVIDER TO PROVIDE DATA  
TELECOMMUNICATION NETWORK SERVICES, LEASE AND MAINTENANCE  
SERVICES FOR A PERIOD OF TEN (10) YEARS.**

**VOLUME 1A.**

**OCTOBER 2023**

**The information contained within this document is confidential to ATNS in all respects and it is hereby acknowledged that the information provided shall only be used for the preparation of a response to this document. The information furnished will not be used for any other purpose than stated and that the information will not directly or indirectly, by agent, employee or representative, be disclosed either in whole or in part, to any other third party without the express written consent by the Company or its representative.**

<b>REFERENCE NUMBER:</b>	<b>ATNS/OT/RFP041/23.24/DATA LINKS</b>
<b>DESCRIPTION:</b>	<b>APPOINTMENT OF A SERVICE PROVIDER TO PROVIDE DATA TELECOMMUNICATION NETWORK SERVICES, LEASE AND MAINTENANCE SERVICES FOR A PERIOD OF TEN (10) YEARS.</b>
<b>ISSUE DATE:</b>	<b>11 OCTOBER 2023</b>
<b>CLOSING DATE:</b>	<b>16 NOVEMBER 2023</b>
<b>CLOSING TIME:</b>	<b>13H00, CAT</b>
<b>COMPULSORY VIRTUAL BRIEFING SESSION VIA MS TEAMS PLATFORM:</b>	<p>DATE: 20 October 2023          VENUE: Teams Meeting          TIME: 11h00-12h00</p> <p>Bidders who are interested to attend must send an email to <a href="mailto:Olwethuf@atns.co.za">Olwethuf@atns.co.za</a> and copy <a href="mailto:tenders@atns.co.za">tenders@atns.co.za</a> to receive invite.</p> <p><b>Last date for requesting for the link is on the 19 October 2023 @ 14:00</b></p>
<b>DEPOSITED IN THE BID BOX SITUATED AT:</b>	<p>ATNS Company Limited,          Eastgate Office Park, Block C,          South Boulevard Road,          Bruma,2298</p> <p>OR</p> <p>Should a bidder require to submit their documents online, they must send an email to <a href="mailto:Olwethuf@atns.co.za">Olwethuf@atns.co.za</a> and copy <a href="mailto:tenders@atns.co.za">tenders@atns.co.za</a> to express their interest to do so.</p> <p>On the email Bidders must specify on the subject line – the tender number and description.</p> <p>A link will be shared with the Bidder upon receipt of their intention to submit a bid online.</p> <p><b>Deadline for requesting the link is 2 days before closing date, email sent after this deadline will not be attended to.</b></p>

## TABLE OF CONTENTS

<b>important Notice</b> .....	5
1. Section A: Introduction And Scope Of Work.....	6
1.1. Introduction.....	6
1.2. Objective.....	8
1.3. Scope Of Work.....	8
1.4. Appendix A : Technical Specifications.....	9
1.5. Validity Period.....	18
1.6. Correspondence During Bid Period.....	19
1.7. The Bid Shall Be delivered.....	19
1.8. Tender Briefing Session.....	20
1.9. Clarifications.....	20
1.10. Procedures For Submitting Of Bids.....	20
2. Section B: Bid Evaluation Process.....	22
2.1. Stage 1: Administrative Requirements.....	22
2.2. Stage 2: Technical Mandatory Evaluation.....	22
2.3. Stage 3: Functionality Evaluation.....	23
2.4. Stage 4: Price And Specific Goals.....	31
3. Section C: Tender Conditions And Instructions To Bid.....	32
3.1. Disclaimer.....	32
3.2. Contract Terms.....	33
3.3. Cancellation Of Procurement Process.....	33
3.4. Bid Submission Conditions, Instruction And Evaluation Process/Criteria.....	33
3.5. Negotiation And Contracting.....	34
3.6. Reasons For Rejection.....	34
3.7. General Conditions Of Contract.....	34
3.8. Additional Information Requirements.....	34
3.9. Confidentiality.....	35
3.10. Intellectual Property, Inventions And Copyright.....	35
3.11. Non-Compliance With Delivery Terms.....	35
3.12. Warrants.....	35
3.13. Parties Not Affected By Waiver Or Breaches.....	35
3.14. Retention.....	35
3.15. Central Supplier Database.....	36
3.16. Format Of Bids.....	36

3.17. Sars Tax Clearance Certificate(S).....	36
3.18. Declaration Of Interest.....	37
3.19. Invitation To Bid.....	37
3.20. Pricing Schedule .....	37
3.21. Registration On The Csd.....	37
3.22. Registration Certificates And Accreditation With Oems Or Professional Boddies .....	37
4. SECTION D: STANDARD BIDDING DOCUMENTS .....	38
SBD1: INVITATION TO BID .....	38
<b>1 PROTECTION OF PERSONAL INFORMATION .....</b>	<b>45</b>
SBD 3.1 - PRICING SCHEDULE – FIRM PRICES .....	48
(PURCHASES).....	48
SBD 4: BIDDER’S DISCLOSURE .....	48
SBD 6.1: PREFERENCE POINTS CLAIM FORM IN TERMS OF THE PREFERENTIAL PROCUREMENT REGULATIONS 2022.....	53
GENERAL CONDITIONS OF CONTRACT.....	59

## BIDDING STRUCTURE

<b>Indicate the type of Bidding/Tendering Structure by marking with an 'X'</b>	
<b>Individual Bidder</b>	
<b>Joint Venture</b>	
<b>Consortium</b>	
<b>With Sub-Contractors</b>	
<b>Other</b>	
<b>If Individual:</b>	
<b>Name of Bidder</b>	
<b>Registration Number</b>	
<b>VAT Registration Number</b>	
<b>Contact Person</b>	
<b>Telephone Number</b>	
<b>Fax Number</b>	
<b>Cell Number(s)</b>	
<b>E-mail Address</b>	
<b>Postal Address</b>	
<b>Physical Address</b>	
<b>If Joint Venture or Consortium, indicate the name/s of the partners:</b>	
<b>Company Name</b>	
<b>Registration Number</b>	
<b>VAT Registration Number</b>	
<b>Contact Person</b>	
<b>Telephone Number</b>	
<b>E-mail Address</b>	
<b>Fax Number</b>	
<b>Postal Address</b>	
<b>Physical Address</b>	

## IMPORTANT NOTICE

The information contained herein, is given without any liability whatsoever to Air Traffic & Navigation Services Company Limited (ATNS) and no representation or warranty, express or implied, is made as to the accuracy, completeness, or thoroughness of the content of this Request for Proposal (RFP).

This RFP is for the confidential use of only those persons/companies who are participants of this RFP. Each recipient acknowledges that the contents of this RFP are confidential and agrees that it will not without the prior written consent of ATNS, reproduce, use or disclose such information in whole or in part, to any other party other than as required by law or other regulatory requirements.

The Bidder shall bear all costs incurred by him in connection with the preparation and submission of his Bid Response and for finalisation of the contract and the attachments thereof. ATNS will in no case be responsible for payment to the Bidder for these costs. The Company reserves the right to reject any or all Bids, to undertake discussions with one or more Bidders, and to accept that Bid or modified Bid which in its sole judgment, will be most advantageous to the Company, price and other evaluation factors having been considered.

## 1. SECTION A: INTRODUCTION AND SCOPE OF WORK

---

### 1.1. Introduction

The Air Traffic and Navigation Services (ATNS) Company of South Africa is the major provider of air traffic management, communication, surveillance, navigation, and associated services (including training) within South Africa. ATNS manages 10% of the world's airspace.

Standing strong with over 1100 employees, ATNS strives to continuously provide safe airspace, orderly, expeditious and efficient management of Air Traffic Management services. The company operates at 21 aerodromes within the country, including OR Tambo, Cape Town, and King Shaka International Airports. In the rest of the African Continent, ATNS provides amongst others the Aeronautical Satellite Communication (VSAT) networks. This service extends from Cape to Cairo interconnecting more than 33 states in Africa and Middle East. Other services include ATS and technical training, WGS 84 surveys, airspace design, AIP documentation, billing, and consultancy services.

#### **Vision**

ATNS's Vision is to be the preferred supplier of air traffic management solutions and associated services to the African continent and selected international markets.

#### **Mission**

Our Mission is to provide safe, expeditious and efficient air traffic management solutions and associated services, whilst ensuring long-term economic, social and environmental sustainability.

- Our business is driven through our embedded Values, being:
- Accountability
- Safety and customer service
- Continuous improvement and innovation
- Employee engagement and development
- Fairness and consistency
- Open and effective communication

The Air Traffic and Navigation Service Company Limited (ATNS) is a State-Owned Company (SOC), established in 1993 in terms of the ATNS Company Act (Act 45 of 1993) to provide air traffic management solutions and associated services on behalf of the State. These services accord with International Civil Aviation Organisation (ICAO) standards and recommended practices, and the South African Civil Aviation Regulations and Technical Standards. As an air navigation services provider (ANSP), ATNS is governed by the nation's legislative and administrative framework.



ATNS is also a commercialised ANSP operating on the “user pays” principle that relies on current revenues and debt funding for its operational and capital expenditure requirements.

Our business offerings are divided into Regulated and non-regulated activities:

### **Regulated Business**

At present 90% of ATNS’s revenue is facilitated through its regulated business:

#### **Air navigation services and infrastructure**

The principal activities of ATNS’s regulated business encompass the planning, operating and maintenance of safe and efficient air traffic management services in the airspace for which the State is responsible. Airspace infrastructure consists of the following main components:

- Communications, navigation and surveillance (CNS) infrastructure.
- Auxiliary aviation services, such as aeronautical information publications, flight procedure design and aeronautical surveys.
- Air traffic management.

ATNS’s infrastructure development is informed by user expectations and regulatory requirements at a global level; as well as the needs of the air traffic management (ATM) community and new enabling technologies.

#### **Air traffic service charges**

As a monopoly service provider, ATNS is regulated economically by the Economic Regulating Committee (RC) that is a statutory body formed and appointed by the Shareholder, the Department of Transport (DoT). The RC is empowered by the ATNS Company Act (Act 45 of 1993) to issue permission to ATNS. The permission regulates the increase in specified tariffs that ATNS can issue and lays down minimum service standards requirements for the regulated business. ATNS is, through the permission, authorized to levy air traffic service charges on users (aircraft operators) for the use of air navigation infrastructure and/or the provision of an air traffic service. The permission has a five-year life span.

#### **Training institution**

ATNS runs a successful training institution as a division within the Company, namely: the Aviation Training Academy (ATA). The ATA provides a full range of air traffic services training, technical support training and related training to delegates in South Africa and the broader African continent in the disciplines of engineering, air traffic services and management. The ATA is an ISO9001:2000 accredited institution and has international cooperation agreements in place with partners, enabling the academy to maintain mutually beneficial partnerships in the presentation and accreditation of international courses in air traffic services (ATS). The ATA is a world-renowned academy, and in both 2012 and 2013 was formally recognized as the International Air Transport Association (IATA) Worldwide Top Regional Training Partner.



## **Non-Regulated Business**

ATNS's non-regulated business currently contributes 10% of the Company's revenue. The non-regulated business encompasses a long-term strategy to facilitate regional expansion through a subsidiary vehicle presently known as "ATNS International". ATNS International will enable the Company to take a more robust and agile stance in the non-regulated business market without posing undue risks to its regulated market and Shareholder. It will also enable ATNS to enter joint ventures and partnerships with external suppliers so that the Company can harness more valuable market opportunities and extend its regional influence and reach. Additional information is available on ATNS website – [www.atns.com](http://www.atns.com)

### **1.2. OBJECTIVE**

Air Traffic and Navigation Services SOC seeks to appoint a service provider to provide a communication (DATA AND VOICE/VOIP) network services, lease, and maintenance services at ATNS Control centres and remote sites for a period of the (10) years.

### **1.3. SCOPE OF WORK**

The appointed service provider is expected to provide the following:

- 1.3.1.** The Communication (Data and Voice) Network Services bid is aimed at assisting ATNS to accomplish its risk management objectives by ensuring that ATNS Centres and its remote sites are supplied with data and voice links that are maintained, serviced, repaired, and restored to their normal operating conditions to support the required service level.
- 1.3.2.** The objective of this bid is to appoint a suitable experienced Communication (Data and Voice) Network Service Provider that can provide assurance to ATNS Management in discharging its responsibilities regarding Communication (Data and Voice) Network Services. The Bidder must demonstrate the capability to provide and perform effective Communication (Data and Voice) Network Services in accordance with all legal and statutory requirements.
- 1.3.3.** Service providers are herewith invited to submit a proposal for the Communication (Data and Voice) Network Services Lease and Maintenance Services at ATNS Main Centres and local/remote sites for a period of ten (10) years.

1.3.4. The provision of additional Communication (Data and Voice) Network Services and VOIP Base Telephony services on an AD-HOC basis as required by ATNS management on a quotation basis. Bidders shall provide pricing rates over ten (10) years on the attached Pricing & Payment Schedule spreadsheet.

#### 1.4. APPENDIX A: TECHNICAL SPECIFICATIONS

##### 1.4.1. Detailed Specifications

The Systems that require data networks are divided into the following (four) 4 classes, namely:

- i) VHF Radios System and Equipment Status
- ii) Radar System and Equipment Status
- iii) TopSky Display System
- iv) Telephone Exchange

Details per class are provided below:

##### 1.4.1.1 VHF Radios System and Equipment Status

System Types	Existing Services	Proposed Solution	Requirements
<b>VHF Radios System and Equipment Status</b>	Audio: 4 Wire E&M	Ethernet (Convertible to 4 Wire E&M)	<p><b><u>VHF System:</u></b></p> <p>Compliance with EUROCAE ED138 standard (Network Requirements and Performance for VOIP in Air Traffic Management) with regards to the network performance requirements:</p> <ol style="list-style-type: none"> <li>1. One-way Latency time max &lt;50ms</li> <li>2. Jitter &lt; 15ms</li> <li>3. Packet Loss &lt; 0.5%</li> <li>4. Availability: 99.98%</li> </ol> <p>Minimum bandwidth requirements:</p>
	Status: RS232	RS232 (Convertible to Ethernet)	

System Types	Existing Services	Proposed Solution	Requirements
			100kbps per voice channel (TX and RX). Some sites have up to 5 VHF radio channels 100kbps for RCMS (future SNMP based).

Table A1: VHF Radios System and Equipment Status

**a. Communication (Data and Voice) Network Services Requirement**

- One-way Latency time max <50ms
- Jitter < 15ms
- Packet Loss < 0.5%
- Availability: in line with Table B4
- Minimum bandwidth requirements:100kbps per voice channel (TX and RX).  
Some sites have up to 5 VHF radio channels 100kbps for RCMS (future SNMP-based)

The IP links must comply with EUROCAE ED138 standard (Network Requirements and Performance for VOIP in Air Traffic Management)

**Audio: 4 wire E&M Details**

**a. VHF T6 Radios**

**T6 Transmitter**

Audio - & Audio: Balanced 600ohm -30dBm to +10dBm.

Signalling / PTT: PTT reference can be set to 14V, 0V, or – 14 V. Maximum input level +-60V with respect to the reference. Input will draw no more than 6mA and requires at least 1 mA to operate. When the input PTT signal and the PTT reference differ by more than 10V the radio keys. When the input PTT signal and PTT reference are within 1V, the radio dekeys.

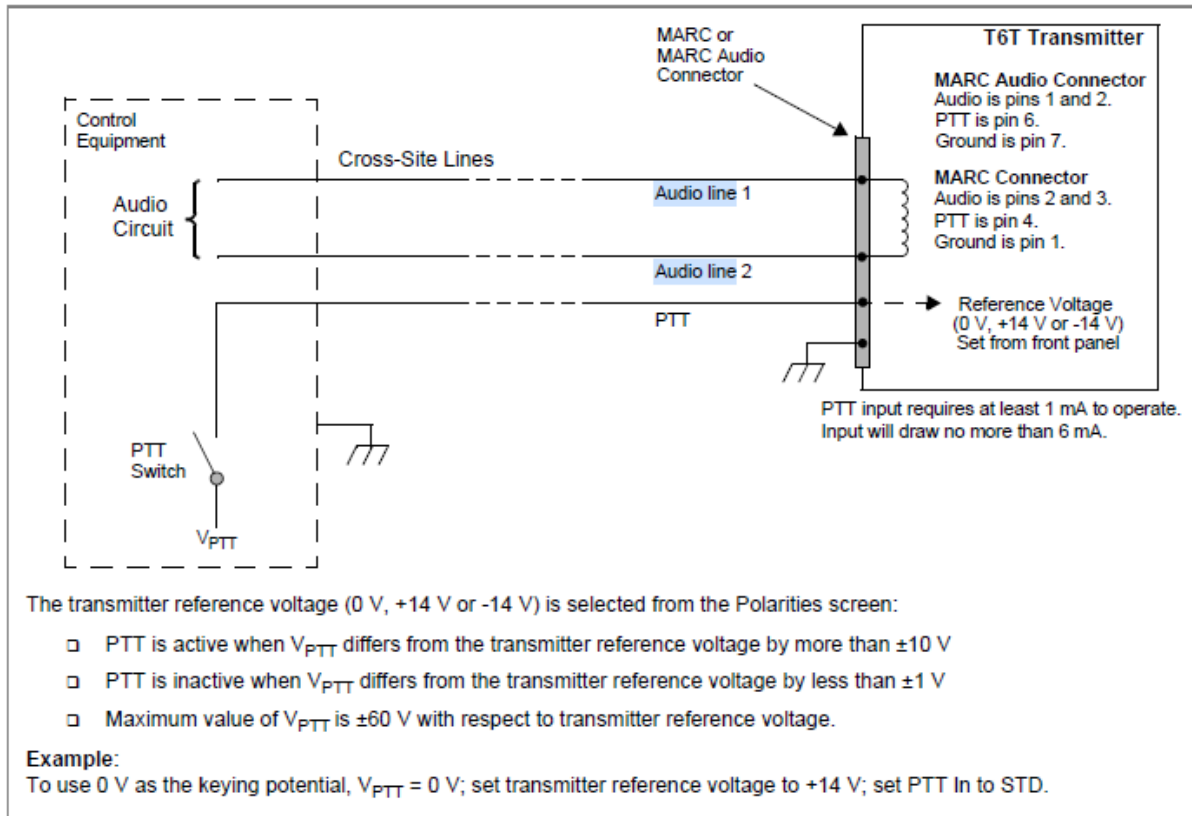

### T6 Receiver

Audio - & Audio +: Balanced 600ohm -30dBm to +10dBm

Signalling / Squelch: Solid state relay, +60 to -60 Vac or dc, 100mA maximum configurable normally open or normally closed. Contact closure time is less than 20ms.

Data: RSE MARC RS232 (ranging between 2400bps to 250Kbps).

### **b. VCCS Rev C**

Audio - & Audio: 600 Ohms balanced line. Bandwidth 300 Hz to 3400 Hz, according to ITU-T G.71. The signal level is individually adjustable for input and output audio within a range of -25 dBm to + 5dBm. Noise < - 65 dBm0p, according to ITU-T G.712. Signal to noise ratio > 65 dB at nominal level. Harmonic Distortion < -46 dB @ 1000Hz, 0dBm.

Signalling / PTT: Ground output to the communication medium.

Signalling / Squelch: Less than negative 13 volts.

### 1.4.1.2 Radar System and Equipment Status

System Types	Existing Services	Proposed Solution	Requirements
<b>Radar System and Equipment Status</b>	RS 232 Synchronous Data Serial 19200 Baud	Ethernet	<b><u>Radar Systems:</u></b> <ul style="list-style-type: none"> <li>▪ Maximum One-Way Delay: 300ms for 99.9% of packets within a 10-minute interval.</li> <li>▪ Maximum Packet Loss: 0.1% from all packets within a 10-minute interval.</li> <li>▪ Minimum Guaranteed Bandwidth: 256 kbps.</li> <li>▪ UDP/TCP effective throughput: 230 kbps.</li> <li>▪ Availability: 99.98%.</li> </ul>
	Ethernet		

Table B2: Radar System and Equipment Status

### 1.4.1.3 TopSky Display System

System Types	Existing Services	Proposed Solution	Requirements
<b>TopSky Display System</b>	X21	Ethernet	<b>TopSky system CDP Link (4 x OR Tambo and 3 x Cape Town):</b> <ul style="list-style-type: none"> <li>▪ Central Data Processor (CDP) links latency between 50ms to 100ms maximum. Higher latencies start to impact on TopSky system response time experiences of ATC actions and cannot be allowed.</li> <li>▪ Real-time environment. <ul style="list-style-type: none"> <li>- CDP links bandwidth <math>\geq</math> 1Mbps (Minimum 1Mbps)</li> </ul> </li> </ul>

System Types	Existing Services	Proposed Solution	Requirements
			<ul style="list-style-type: none"> <li>- CDP link packet drops &lt;1%</li> <li>- Separate NODES to be used for TopSky</li> <li>▪ CDP links. Meaning, one node per set of CDP links with no other links on the node – if it is unavoidable to combine other systems’ links on a particular node, then the bandwidth has to be increased to allow for 1Mbps per CDP link.</li> </ul>

Table B3: TopSky Display System

#### 1.4.1.4 Telephone Exchange

#### 1.4.2. Sites Details

The successful service provider will be required to provide leased data links on the sites and associated performance requirements below.

Site Name	Bandwidth Requirements	Convert to	Minimum Availability	Maximum Latency	Maximum downtime per year
		4 Wire E & M and RS323			
<b>OR Tambo</b>					
OR Tambo Control Centre (VHF, Radar & TopSky) (4 Devices (Routers))	16 Mbps	NO	99.98%	100ms	1 hour 45 minutes
OR Tambo ATNS OPS Centre - SSS (new)	4Mbps	NO	99.98%	100ms	1 hour 45 minutes
Ellisras Forward Relay VHF Radio Services	2Mbps	YES	99.50%	100ms	1 day 19 hrs 28min
Mahikeng Forward Relay VHF Radio Services	2Mbps	YES	99.50%	100ms	1 day 19 hrs 28min
Groothoek Forward Relay VHF Radio Services	2Mbps	YES	99.50%	100ms	1 day 19 hrs 28min

Site Name	Bandwidth Requirements	Convert to	Minimum Availability	Maximum Latency	Maximum downtime per year
		4 Wire E & M and RS323			
Hartbeesfontein Forward Relay VHF Radio Services	2Mbps	YES	99.50%	100ms	1 day 19 hrs 28min
Jericho Forward Relay VHF Radio Services	2Mbps	YES	99.50%	100ms	1 day 19 hrs 28min
Kaapsehoop Forward Relay VHF Radio Services	2Mbps	YES	99.50%	100ms	1 day 19 hrs 28min
Leeuwkop Forward Relay VHF Radio Services	2Mbps	YES	99.50%	100ms	1 day 19 hrs 28min
Louis Trichardt Forward Relay VHF Radio Services	2Mbps	YES	99.50%	100ms	1 day 19 hrs 28min
Mauchberg Forward Relay VHF Radio Services	2Mbps	YES	99.50%	100ms	1 day 19 hrs 28min
Potgietersrus Radar Services	2Mbps	NO	99.50%	100ms	1 day 19 hrs 28min
Potgietersrus Forward Relay VHF Radio Services (Dual routers (devices))	2Mbps	YES	99.50%	100ms	1 day 19 hrs 28min
Renosterkop (Rustig) Forward Relay VHF Radio Services	2Mbps	YES	99.98%	100ms	1 day 19 hrs 28min
Vryburg Forward Relay VHF Radio Services	2Mbps	YES	99.98%	100ms	1 day 19 hrs 28min
Nelspruit Kruger Radar Services	2Mbps	NO	99.50%	100ms	1 day 19 hrs 28min
Nelspruit Kruger Forward Relay VHF Radio Services	2Mbps	YES	99.50%	100ms	1 day 19 hrs 28min
Bapsfontein HF/VHF Radio Services (Receivers Only) (Dual routers (devices))	4Mbps	YES	99.50%	100ms	1 day 19 hrs 28min
Isando HF Radio Services (Transmitters Only) (Dual routers (devices))	4Mbps	YES	99.50%	100ms	1 day 19 hrs 28min
Delmas HF Radio Services (Transmitters Only) (Dual routers (devices))	4Mbps	YES	99.50%	100ms	1 day 19 hrs 28min



Site Name	Bandwidth Requirements	Convert to	Minimum Availability	Maximum Latency	Maximum downtime per year
		4 Wire E & M and RS323			
Lanseria Airport Control Centre (TopSky) (Dual routers (devices))	4Mbps	NO	99.50%	100ms	86 hours 56 minutes
<b>Bloemfontein</b>					
Bloemfontein Airport Control Centre (VHF, Radar & TopSky) (Dual routers (devices))	6Mbps	NO	99.98%	100ms	1 hour 45 minutes
Noupoort Forward Relay VHF Radio Services	2Mbps	YES	99.50%	100ms	1 day 19 hrs 28min
Tafelkop Radar Services	2Mbps	YES	99.50%	100ms	1 day 19 hrs 28min
Tafelkop Forward Relay VHF Radio Services	2Mbps	YES	99.50%	100ms	1 day 19 hrs 28min
Victoria West Forward Relay VHF Radio Services	2Mbps	YES	99.50%	100ms	1 day 19 hrs 28min
Northbank (Gariepdam) Forward Relay VHF Radio Services	2Mbps	YES	99.50%	100ms	1 day 19 hrs 28min
De Aar Forward Relay VHF Radio Services	2Mbps	YES	99.50%	100ms	1 day 19 hrs 28min
De Aar Radar Services	2Mbps	NO	99.50%	100ms	1 day 19 hrs 28min
Kimberly Forward Relay VHF Radio Services (Dual routers (devices))	2Mbps	YES	99.50%	100ms	1 day 19 hrs 28min
Bethlehem Forward Relay VHF Radio Services	2Mbps	YES	99.50%	100ms	1 day 19 hrs 28min
Pofadder (Repl Aggeneys) (new) Forward Relay VHF Radio Services	2Mbps	YES	99.50%	100ms	1 day 19 hrs 28min
Klein Begin (Repl Upington) Forward Relay VHF Radio Services	2Mbps	YES	99.50%	100ms	1 day 19 hrs 28min



Site Name	Bandwidth Requirements	Convert to	Minimum Availability	Maximum Latency	Maximum downtime per year
		4 Wire E & M and RS323			
Kuruman Hills (Repl Kathu) (new) Forward Relay VHF Radio Services	2Mbps	YES	99.50%	100ms	1 day 19 hrs 28min
Prieska Forward Relay VHF Radio Services	2Mbps	YES	99.50%	100ms	1 day 19 hrs 28min
<b>Cape Town</b>					
Cape Town Airport Control Centre (VHF, Radar & TopSky) (4 Devices (Routers))	10Mbps	NO	99.98%	100ms	1 hour 45 minutes
Cape Town International Airport - SSS (new)	4Mbps	NO	99.98%	100ms	1 hour 45 minutes
Leliefontein Forward Relay VHF Radio Services	2Mbps	YES	99.50%	100ms	1 day 19 hrs 28min
Calvinia Forward Relay VHF Radio Services	2Mbps	YES	99.50%	100ms	1 day 19 hrs 28min
Springbok (Repl Alex Bay) Forward Relay VHF Radio Services	2Mbps	YES	99.50%	100ms	1 day 19 hrs 28min
Beaufort West Forward Relay VHF Radio Services	2Mbps	YES	99.50%	100ms	1 day 19 hrs 28min
Pieketberg Forward Relay VHF Radio Services	2Mbps	YES	99.50%	100ms	1 day 19 hrs 28min
Villiersdorp (Jonaskop) Forward Relay VHF Radio Services	2Mbps	YES	99.50%	100ms	1 day 19 hrs 28min
<b>Port Elizabeth</b>					
Port Elizabeth Control Centre (Dual routers (devices))	4Mbps	NO	99.98%	100ms	1 hour 45 minutes
Humansdorp Forward Relay VHF Radio Services	2Mbps	YES	99.50%	100ms	1 day 19 hrs 28min
Port Elizabeth Radar Services	2Mbps	NO	99.50%	100ms	1 day 19 hrs 28min

Site Name	Bandwidth Requirements	Convert to	Minimum Availability	Maximum Latency	Maximum downtime per year
		4 Wire E & M and RS323			
<b>George</b>					
George Airport Control Centre (Dual routers (devices))	4Mbps	NO	99.98%	100ms	1 hour 45 minutes
Blesberg Radar Services	2Mbps	YES	99.50%	100ms	1 day 19 hrs 28min
Blesberg Forward Relay VHF Radio Services (Dual routers (devices))	2Mbps	YES	99.50%	100ms	1 day 19 hrs 28min
Potjiesberg Forward Relay VHF Radio Services	2Mbps	YES	99.50%	100ms	1 day 19 hrs 28min
<b>La Mercy</b>					
La Mercy Airport Control Centre (VHF, Radar & TopSky)(3 routers (devices))	8Mbps	NO	99.98%	100ms	1 hour 45 minutes
Virginia Airport Forward Relay VHF Radio Services (Dual routers (devices))	2Mbps	YES	99.50%	100ms	1 day 19 hrs 28min
Pietermaritzburg Forward Relay VHF Radio Services (Dual routers (devices))	2Mbps	YES	99.50%	100ms	1 day 19 hrs 28min
Durban Bluff Radar Site Forward Relay VHF Radio Services	2Mbps	YES	99.50%	100ms	1 day 19 hrs 28min
Durban Bluff Radar Services	2Mbps	YES	99.50%	100ms	1 day 19 hrs 28min
Louwsburg Forward Relay VHF Radio Services	2Mbps	YES	99.50%	100ms	1 day 19 hrs 28min
Mount Ayliff Forward Relay VHF Radio Services	2Mbps	YES	99.50%	100ms	1 day 19 hrs 28min
<b>East London</b>					
East London Airport Control Centre	4Mbps	NO	99.98%	100ms	1 hour 45 minutes

Site Name	Bandwidth Requirements	Convert to	Minimum Availability	Maximum Latency	Maximum downtime per year
		4 Wire E & M and RS323			
(Dual routers (devices))					
ATNS East London Local VHF Radio Services	2Mbps	YES	99.50%	100ms	1 day 19 hrs 28min
ATNS East London Radar Services	2Mbps	YES	99.50%	100ms	1 day 19 hrs 28min
Mount Madeira (Queenstown) Forward Relay VHF Radio Services	2Mbps	YES	99.50%	100ms	1 day 19 hrs 28min

Table B4: Site and performance Details

### 1.4.3. ATNS Control Centres

Airport	Province
<b>O R Tambo International Airport</b>	<b>Gauteng</b>
<b>Cape Town International Airport</b> <b>George Airport</b>	<b>Western Cape</b>
<b>King Shaka International Airport</b>	<b>KwaZulu Natal</b>
<b>Bram Fischer International Airport</b>	<b>Free state</b>
<b>King David Stuurman Airport</b> (Old Name: Port Elizabeth Airport) <b>King Phalo Airport</b> (Old Name: East London Airport)	<b>Eastern Cape</b>

Table B5: ATNS Control Centres

## 1.5. Validity Period

**1.5.1.** The proposal provided to ATNS in terms of this request for proposals must be valid for a period of 120 days from the date of submission.

1.5.2. Should there be a need to request extension of the finalisation of the award of the RFP, the bidders will be duly informed, and the priced proposal will remain valid for the amended duration.

**1.6. Correspondence during Bid Period**

1.6.1. All correspondence, during the bidding period in connection with the Bid, shall be made as follows:

All correspondence to ATNS shall be in writing and addressed to:

Procurement Specialist: Olwethu Fakude – [olwethuf@atns.co.za](mailto:olwethuf@atns.co.za) and copy [tenders@atns.co.za](mailto:tenders@atns.co.za)

1.7. The Bid shall be delivered as a complete submission, which shall comprise of:

1.7.1. **PARCEL A** - Commercial Proposal; Financials and Price Structure (Response to Volume 1A, and 1C); and

1.7.2. **PARCEL B** - Technical Proposal (Response to Technical Specifications)

**PARCEL A - COMMERCIAL PROPOSAL; FINANCIALS AND PRICE STRUCTURE. - LABELLED AND TABBED AS PER INDEX.**

Parcel A Index	Requirement	Confirm Submission with X
<b>SBD Forms</b>	Bidders shall submit a complete and signed SBD Forms	
<b>Volume 1 A</b>	South African companies shall submit certified copy of a valid B-BBEE Status Level Verification Certificate from SANAS and or valid EME Sworn Affidavit certified by the commissioner of oath.	
<b>Volume 1 A</b>	South African companies shall submit their: (1) Central Supplier Database summary reports (2) Tax Clearance PIN (3) ID copies of members/directors (4) Banking Details and (5) Company registration docs	
<b>Volume 1 C</b>	Pricing Schedule (in a separate envelope)	

**PARCEL B FUNCTIONAL PROPOSAL: RESPONSE TO THE SCOPE.**

Parcel B Index	Technical Proposal	Confirm Submission with X
B1	Technical System Specifications	

**1.8. Tender Briefing Session**

There will be a **compulsory tender briefing session** for this tender:

Activity	Date	Venue	Time / meeting
Compulsory Briefing session	20 October 2023	<p><b>VIRTUAL COMPULSORY TENDER BRIEFING SESSION WILL BE HELD VIA TEAMS PLATFORM:</b></p> <p>Bidders who are interested to attend must send an email to <a href="mailto:Olwethuf@atns.co.za">Olwethuf@atns.co.za</a> and copy <a href="mailto:tenders@atns.co.za">tenders@atns.co.za</a> to receive invite.</p>	Time: 11h00-12h00

Any clarification required by a bidder regarding the meaning or interpretation of the Terms of Reference, or any other aspect concerning the bid, is preferably to be requested at the briefing session. Bidders are advised to study this document before joining the session and to have all their questions ready.

**1.9. Clarifications**

Any clarification required by a bidder regarding the meaning or interpretation of the Terms of Reference, or any other aspect concerning the bid, is to be requested in writing by completing Form of Questionnaire and email to [olwethuf@atns.co.za](mailto:olwethuf@atns.co.za) and copy [tenders@atns.co.za](mailto:tenders@atns.co.za) not later than 12:00 CAT on the 9<sup>th</sup> of November 2023. A reply will be published on the ATNS website [www.atns.co.za](http://www.atns.co.za) under the Tenders section. The bid reference number should be mentioned in all correspondence. Telephonic requests for clarification will not be accepted. If appropriate, the clarifying information will be made available to all bidders by e-mail only.

**1.10. Procedures For Submitting of Bids**

**1.10.1.** The closing date and time for submitting quotations is 16 November 2023 @ 13h00, CAT.

- 1.10.2.** All prospective bidders must send their bid response submissions to ATNS before or on the closing date and time.
- 1.10.3.** Bidders are now permitted to submit their documents either online or hard copies. Should a bidder require to submit their documents online, they must send an email to [olwethuf@atns.co.za](mailto:olwethuf@atns.co.za) and copy [tenders@atns.co.za](mailto:tenders@atns.co.za) to express their interest to do so. A link will be shared with the supplier for uploading the documents on a secure online portal. On the email Bidders must specify on the subject line – the tender number and description. **Deadline for requesting the link is 2 days before closing date, email sent after this deadline will not be attended to.**
- 1.10.4. In case submitting hard copies,** Bids shall be submitted in two separate Parcels A and B, each parcel shall contain; 1 (one) original and One (1) copy and One (1) soft copy (PDF format) on a movable storage medium (USB), each sealed and addressed in accordance with the following requirements, The name and address of the Bidder; and the Bid Number
- 1.10.5.** The closing date of the Bid indicated on the envelope.
- 1.10.6.** A Cover Letter, signed by the authorised representative of each member of the Bidding Entity, Consortium or Joint Venture, which shall contain:
- 1.10.7.** List of Bid Proposal Documents and an Index of the contents therein;
- 1.10.8.** Particular points to which the Bidder wishes to draw the Company's attention in his Commercial Proposal and Technical Proposal.
- 1.10.9.** The parcels shall not contain documents relating to any Bid other than that shown on the envelope.
- 1.10.10.** Within each parcel, each document shall be individually packaged in a sealed envelope, assigned an identification number and clearly marked with either the designation "Original" or "Copy", as applicable. When referencing another related document this identification number shall be indicated. Each document which is a copy shall be marked and numbered as "Copy 1/2".
- 1.10.11.** All Bid Response documents to be submitted shall be hand delivered to the Company not later than the time and date specified on this document.
- 1.10.12.** No Bids forwarded by telegram, telex, facsimile will be considered. Pricing must be submitted in a separate sealed envelope in Parcel A as Volume 1C. The original copy **MUST BE SIGNED IN BLACK INK** by an authorised employee, agent or representative of the Bidder and initialized on each page of the Bid Response.
- 1.10.13.** Bid responses sent by post or courier must reach this office at least thirty-six (36) hours before the closing date as specified, to be deposited into the Bid Box.

Failure to comply with this requirement will result in the proposal/Bid response being treated as a “late proposal/response” and will not be entertained.

**1.10.14.** The Bid Documents shall be hand delivered to:

ATNS Company Limited,  
Eastgate Office Park, Block C,  
South Boulevard Road,  
Bruma,  
2298  
South Africa.

**1.10.15.** Bidders should allow time to access the premises due to security arrangements that need to be observed.

## **2. SECTION B: BID EVALUATION PROCESS**

---

### **Bid Evaluation Process**

The bid evaluation process for this RFP will be conducted in four (4) distinct stages as follows:

#### **2.1. Stage 1: Administrative Requirements**

All prospective bidders must comply with the following administrative requirement:

- 2.1.1.** Must be registered on the National Treasury CSD (Central Supplier database): A full report must be submitted.
- 2.1.2.** Fully completed and signed Standard Bidding Documents (SBD) forms: (SBD 1, Form D, SBD 3.1, SBD 4, SBD 6.1.): duly completed and signed by the duly authorised person.
- 2.1.3.** Tax Pin, Company registration documents, Bank details, and ID copies of the directors.

If the Bidder failed to comply with any of the administrative requirements, or if ATNS is unable to verify whether the requirements are met, then ATNS reserves the right to-

- a) Reject the bid and not evaluate it, or
- b) Accept the bid for evaluation, on condition that the Bidder must submit within 7 (seven) days any supplementary information to achieve full compliance, provided that the supplementary information is administrative and not substantive in nature.

#### **2.2. Stage 2: Technical Mandatory Evaluation**

During this stage Bid response documentation will be evaluated against compliance to the Technical Specifications. The Technical Mandatory Requirements are listed below, it



is important that you submit all the documentation requested below or you will be disqualified. FAILURE TO SUBMIT ANY OF THE BELOW MANDATORY DOCUMENTS WILL RESULT IN A DISQUALIFICATION AND BIDDER WILL NOT BE EVALUATED FURTHER.

Mandatory Criteria	Proof Required
Bidders must submit a minimum of three (3) Reference letters that serve as proof of previous relevant experience (i.e., Communication (Data and Voice) Network Service Provision) for work completed within the last five (5) years.  <b>Reference letters must be in the client’s letterheads, dated and signed by the referee.</b>	Yes
The bidder must have a valid license to operate in South Africa as a registered Internet Service Provider (ISP): The bidder must submit a valid ICASA license as proof that they are licensed to operate and provide ISP services in the form of an Electronic Communication Network Services (ECNS) Licenses (in the primary bidder’s name). Proof must be submitted with the tender submission.	Yes
Provide certificate for ISO/IEC 27001 information security management system (ISMS) Certification or equivalent	Yes
The bidder shall complete and provide details of the proposed datalink types for each site (e.g., fiber optic, SDH, microwave link, or any network type that can support the minimum required performance criteria on all the sites listed in Appendix B_Table B5.	Yes

### 2.3. Stage 3: Functionality Evaluation

During this stage Tender response documentation will be evaluated against compliance to the Functional and Technical Specifications.

The evaluation during this stage is based on technical criteria (Functionality). Only bidders achieving a minimum score of 80% points will be evaluated further. The criteria are set out below:

No	Evaluation Criteria	Relative Weight
1	Proposed Network Solution	40%
2	Network Monitoring	5%
3	Proposed Network Solution Performance	30%
4	Network Security	20%



5	Project Management and Implementation Requirements	5%
<b>Grand Total</b>		<b>100%</b>

The Bidder shall submit all responses, diagrams, documentation, and drawings according to the GENERAL INFORMATION AND INSTRUCTIONS TO BIDDER'S document and in the English language.

ALL RESPONSES TO THE REQUIREMENTS IN THIS DOCUMENT SHALL BE PROVIDED AS FOLLOWS:

BIDDERS SHALL RESPOND IN FULL TO EACH ITEM IN THE FORMAT PROVIDED AND REFERENCES (CHAPTER, SECTION, PAGE NUMBER, PARAGRAPH NUMBER) TO DOCUMENTS AND RELEVANT INFORMATION SUPPORTING THE RESPONSES SHALL BE INDICATED IN THE SPACE PROVIDED. THIS INFORMATION WILL BE THE **ONLY RESPONSE USED FOR THE EVALUATION AND ASSESSMENT.**

Responses, provided in the space allowed, that are not clear or inadequate or the lack thereof shall be interpreted as **"Not Compliant"** even though the compliance column is declared as "Comply" and/or the Bidder's offer meets the requirement. Bidders shall ensure that each response correctly addresses the requirement stated. Responses not addressing the requirement of the specific paragraph shall be interpreted as **"Not Compliant"**.

Bidders shall declare compliance to each and every paragraph of this document, based on the paragraph classification, in the response block provided opposite the column labelled "Compliance". Bids will be evaluated as follows:

C: fully compliant = 2 points:

PC: partly compliant = 1 point.

NC: not compliant = 0 points.

Bidders shall, for paragraphs declared "PC" or "NC", include a statement as to the nature of the variation and may supply additional supporting information in the space provided to demonstrate how the proposal may still meet the needs of ATNS.

**2.3.1. Proposed Network Solution**

- a. The Bidder shall provide and describe a Communication (Data and Voice) Network Services (network and coverage) in line with the tabulated technical specification for all sites listed in Appendix B\_Table B5.

Compliance (C/PC/NC)	
[Insert Full Response for Evaluation Here]	
[Insert Reference to Additional Information Here]	

- b. The Bidder shall provide and describe a solution that meets the Scope of work in line with the provided Technical Specification.

Compliance (C/PC/NC)	
[Insert Full Response for Evaluation Here]	
[Insert Reference to Additional Information Here]	

- c. The Bidder shall already have an existing Communication (Data and Voice) Network system with a national footprint that has been successfully deployed elsewhere for the purposes of datalink service provision. (Only submissions from Bidders that can prove such success and acceptance shall be evaluated. Bidders shall provide detailed proof of their systems' deployment.

Compliance (C/PC/NC)	
[Insert Full Response for Evaluation Here]	
[Insert Reference to Additional Information Here]	

- d. The Bidder shall provide a detailed technical description of the proposed Communication (Data and Voice) Network Services.

Compliance (C/PC/NC)	
[Insert Full Response for Evaluation Here]	
[Insert Reference to Additional Information Here]	

- e. The proposed Communication (Data and Voice) Network Services shall be backward compatible with 4-wire E&M. Bidder shall provide proof of 4-wire E&M compatibility.
- f. The Bidder shall provide details of the proposed datalink types for each site (e.g., fiber optic, SDH, microwave link, or any network type that can support the minimum required performance criteria on all the sites listed in Appendix B\_Table B4.

Compliance (C/PC/NC)	
[Insert Full Response for Evaluation Here]	
[Insert Reference to Additional Information Here]	

- g. The Bidder shall provide detailed specifications on each of the proposed equipment, including dimensions, for all the specified sites listed in Appendix B\_Table B4.

Compliance (C/PC/NC)	
[Insert Full Response for Evaluation Here]	
[Insert Reference to Additional Information Here]	

- h. The Bidder shall list all the datalink equipment frequency spectrum and associated frequency specifications required for the data transmission for all the specified sites.

Compliance (C/PC/NC)	
[Insert Full Response for Evaluation Here]	
[Insert Reference to Additional Information Here]	

- i. The Bidder shall confirm that the proposed Communication (Data and Voice) Network Services complies in all aspects with the ICASA-approved frequency spectrum(s).

Compliance (C/PC/NC)	
[Insert Full Response for Evaluation Here]	
[Insert Reference to Additional Information Here]	

- j. The Bidder shall include a schematic design diagram(s) that proof that there is a common point of failure(s) and methodology of the proposed Communication (Data and Voice) Network Services as part of their response.

Compliance (C/PC/NC)	
[Insert Full Response for Evaluation Here]	
[Insert Reference to Additional Information Here]	

- k. The Bidder shall include details about the design of Quality of Service (QoS) incorporated in the proposed Communication (Data and Voice) Network Services as part of their response.

Compliance (C/PC/NC)	
[Insert Full Response for Evaluation Here]	
[Insert Reference to Additional Information Here]	

**2.3.2. Network Monitoring**

- a. The Bidder shall provide capabilities on the proposed Communication (Data and Voice) Network Services and access rights for real-time monitoring of the entire Communication (Data and Voice) Network Services performance at the ATNS Centers as listed in **Table B5**.

Compliance (C/PC/NC)	
[Insert Full Response for Evaluation Here]	
[Insert Reference to Additional Information Here]	

**2.3.3. Proposed Network Solution Performance**

- a. The Bidder shall confirm that the proposed Communication (Data and Voice) Network Services shall comply with the Maximum One-Way Delay requirements which is 50ms for 99.9% of packets within a 10-minute interval (See APPENDIX );

<b>Compliance (C/PC/NC)</b>	
[Insert Full Response for Evaluation Here]	
[Insert Reference to Additional Information Here]	

- b. The Bidder shall confirm that the proposed Communication (Data and Voice) Network Services shall comply with the Maximum Packet Loss requirements which is 0.5% from all packets within a 10-minute interval (See APPENDIX );

<b>Compliance (C/PC/NC)</b>	
[Insert Full Response for Evaluation Here]	
[Insert Reference to Additional Information Here]	

- c. The Bidder shall confirm that the proposed Communication (Data and Voice) Network Services shall comply with the Minimum Network Bandwidth requirements (See APPENDIX );

<b>Compliance (C/PC/NC)</b>	
[Insert Full Response for Evaluation Here]	
[Insert Reference to Additional Information Here]	

- d. The Bidder shall provide ATNS with all the network performance parameters and events logging information for the entire Communication (Data and Voice) Network Services during the commissioning period of the project. This includes historic data (graphs) of specific network parameters such as (but not limited to): availability, ping delays, jitter, latency, throughput per endpoint, trace routes, aggregated uptime, TTL

and packet losses, listing minimum, maximum and average values for all parameters; The bidder shall provide a generic sample report showing all the parameter above for evaluation purpose.

<b>Compliance (C/PC/NC)</b>	
[Insert Full Response for Evaluation Here]	
[Insert Reference to Additional Information Here]	

- e. The Bidder shall, on a monthly basis during the Service Level Agreement phase, submit to ATNS all network performance parameters and events logging information of the entire Communication (Data and Voice) Network Services. This includes historic data (graphs) of specific network parameters such as availability, ping delays, jitter, latency, throughput per endpoint, trace routes, aggregated uptime, TTL and packet losses;

<b>Compliance (C/PC/NC)</b>	
[Insert Full Response for Evaluation Here]	
[Insert Reference to Additional Information Here]	

- f. The Bidder shall confirm that the overall Communication (Data and Voice) Network Services shall comply with the ATNS Reliability, Availability and Maintainability (RAM) requirements for a Communication (Data and Voice) Network as detailed for the individual circuits within Table B4 (minimum circuit Availability and Maximum downtime per year):

<b>Compliance (C/PC/NC)</b>	
[Insert Full Response for Evaluation Here]	
[Insert Reference to Additional Information Here]	

**2.3.4. Network Security**

- a. The Bidder shall provide details of the network security features the proposed Communication (Data and Voice) Network Services Solution complies to (e.g., packet and traffic encapsulation and encryption techniques, tunnelling features, user-level access features, denial of services protection etc;

<b>Compliance (C/PC/NC)</b>	
[Insert Full Response for Evaluation Here]	
[Insert Reference to Additional Information Here]	

**2.3.5. Project Management and Implementation Requirements**

- a. The Bidder shall submit a draft plan for testing and accepting all critical elements of the Communication (Data and Voice) Network Services.

<b>Compliance (C/PC/NC)</b>	
[Insert Full Response for Evaluation Here]	
[Insert Reference to Additional Information Here]	

- b. The Bidder shall provide a comprehensive risk management plan, the plan shall identify project-related risks and provide proposed mitigation activities and methods);

<b>Compliance (C/PC/NC)</b>	
[Insert Full Response for Evaluation Here]	
[Insert Reference to Additional Information Here]	

- c. The submitted response shall include the proposed Service Level Agreement (SLA) of the proposed Communication (Data and Voice) Network Services. The proposed SLA shall define in detail the proposed maintenance and support activities that will be carried out for a period of 10 years;

<b>Compliance (C/PC/NC)</b>	
[Insert Full Response for Evaluation Here]	
[Insert Reference to Additional Information Here]	

**2.4. Stage 4: Price and Specific Goals**

2.4.1. The 90/10 preference points system will be utilised for this RFP. This preference points system is for the acquisition of goods or services above a Rand value of R50 million as follows:

Criteria	Means of Verification	Points
Price	Proposed Bid Price	90,00
Preference Points	Specific Goals	10,00
<b>Total Points</b>		<b>100,00</b>

**2.4.2. Pricing Schedule**

Pricing schedule labelled Volume 1 C. on volume 1C, three columns have been created for each region and a bidder should complete ONLY the region bidding for.

**NAME OF THE COMPANY**.....

**DESIGNATION**.....

**SIGNATURE**.....

**CSD NUMBER**.....

**2.4.3. Specific Goals**

**The Preferential Procurement Regulations, 2022 pertaining to the Preferential Procurement Policy Framework Act, Act No 5 of 2000.**

ATNS Preferential Procurement (PP) requirements as per the ATNS Supply Chain Management Policy, states that ATNS shall deal with suppliers in accordance with the ATNS specific goals. The application of the specific goals will be per request, per tender up to the maximum points as per the applicable pricing formula, the 80/20 system.



Suppliers not meeting the requirements of the Preferential Procurement are required to clearly identify any possible teaming arrangement which could be established with South African B-BBEE compliant enterprises Any workable plan to train and promote black businesses or individuals through meaningful participation in this project will be considered favourably by the Company during the RFQ evaluation process.

Partnership must be in the form of Joint Venture Agreement or Consortium Agreement between compliant B-BBEE and non-B-BBEE Organisation/or foreign supplier in order to meet the policy requirements.

All responsive tender offers shall be evaluated in terms of Price and ATNS specific goals. The 80/20 Preference Point System shall be applicable in accordance with the Preferential Procurement Framework Act (No.5) of 2000.

**2.4.3.1. The following allocation will determine the specific goals (10.00 points) for this tender process:**

Category	Points allocated
51% Black Owned Suppliers (Section 2(1)(d)(i) of the PPPFA)	10,00
<b>Total</b>	<b>10,00</b>

**2.4.3.2. Bidders must submit the following documents as a means of verification for specific goals:**

- (a) CSD Report
- (b) CIPC documents (company registration documents),
- (c) Shareholder certificates, and
- (d) Copy/ies of Identity document(s) for shareholder(s).

Bidders who fail to submit the above documents will not qualify for points allocated for specific goals.

**3. SECTION C: TENDER CONDITIONS AND INSTRUCTIONS TO BID**

---

**3.1. DISCLAIMER**

**3.1.1.** The Bidder shall bear all costs incurred in connection with the preparation and submission of their Bid Response and for finalisation of the contract and the attachments thereof. ATNS will in no case be responsible for payment to the Bidder for these costs.

**3.1.2.** The Company reserves the right to reject any or all Bids, to undertake discussions with one or more Bidders, and to accept that Bid or modified Bid which in its sole

judgment, will be most advantageous to the Company, price and other evaluation factors having been considered.

### **3.2. CONTRACT TERMS**

- 3.2.1.** Whilst ATNS have taken every reasonable step to ensure the accuracy of this brief, the Company accepts no liability in relation to the accuracy of any representations made. Bidders should accept that their tender response is on the basis and reliance of its own judgment and information. ATNS reserves the right to vary the scope and terms as described in this document. If any variation does take place tenderer will be advised as soon as possible in writing.
- 3.2.2.** The successful tenderer will be engaged subject to acceptance of a contract containing the standard Terms and Conditions as given. The contract contains standard clauses including a retention clause for non-satisfactory completion, breach of contract and confidentiality clauses and a requirement for the tenderer to have adequate professional indemnity insurance. All Tenderers must bear in mind that if circumstances dictate, ATNS reserves its right to withdraw from any commitments that will be entered into within this statement of work.
- 3.2.3.** All designs and documentation submitted by the tenderer will be treated as confidential.
- 3.2.4.** ATNS reserves the right to reject, withdraw or cancel any or all Proposals/Tenders, to undertake discussions with one or more Tenderers and to accept that tender or modified tender which in its sole judgment, will be most advantageous to the Company, price and other evaluation factors having been considered.

### **3.3. CANCELLATION OF PROCUREMENT PROCESS**

This procurement process can be postponed or cancelled at any stage at the sole discretion of ATNS provided that such cancellation or postponement takes place prior to entering a contract with a specific service provider to which the bid relates.

### **3.4. BID SUBMISSION CONDITIONS, INSTRUCTION AND EVALUATION PROCESS/CRITERIA**

The Bid submission conditions and instructions as well as the evaluation process/criteria have been noted. Non-compliance to any of these will result in a bid being rejected.

### **3.5. NEGOTIATION AND CONTRACTING**

ATNS have the right to enter negotiation with one or more Bidders regarding any terms and conditions, including price(s), of a proposed contract.

Under no circumstances will negotiation with any Bidders, including preferred Bidders, constitute an award or promise/ undertaking to award the contract.

ATNS shall not be obliged to accept the lowest or any bid, offer or proposal.

A contract will only be deemed to be concluded when reduced to writing in a formal contract and Service Level Agreement (if applicable) signed by the designated responsible person of both parties.

ATNS also reserves the right to enter one contract with a Bidder for all required functions or into more than one contract with different Bidders for different functions.

### **3.6. REASONS FOR REJECTION**

ATNS shall reject a proposal for the award of a contract if the recommended Bidder has committed a proven corrupt or fraudulent act in competing for the particular contract.

ATNS may disregard the bid of any bidder if that bidder, or any of its directors:

- Have abused the SCM system of the ATNS.
- Have committed proven fraud or any other improper conduct in relation to such system.
- Have failed to perform on any previous contract and the proof exists.
- Such actions shall be communicated to the National Treasury.

### **3.7. GENERAL CONDITIONS OF CONTRACT**

The General Conditions of Contract must be accepted.

### **3.8. ADDITIONAL INFORMATION REQUIREMENTS**

During evaluation of the bids, additional information may be requested in writing from Bidders. Replies to such request must be submitted, within 7 working days or as otherwise indicated. Failure to comply, may lead to your bid being disregarded.

No additional information will be accepted from any individual Bidder without such information having been requested.

### **3.9. CONFIDENTIALITY**

The bid and all information in connection therewith shall be held in strict confidence by Bidders and usage of such information shall be limited to the preparation of the bid. Bidders shall undertake to limit the number of copies of this document.

### **3.10. INTELLECTUAL PROPERTY, INVENTIONS AND COPYRIGHT**

Copyright of all documentation relating to this contract belongs to the client. The successful Bidder may not disclose any information, documentation, or products to other clients without the written approval of the accounting authority or the delegate. This paragraph shall survive termination of this contract.

### **3.11. NON-COMPLIANCE WITH DELIVERY TERMS**

As soon as it becomes known to the contractor that he/she will not be able to deliver the services within the delivery period and/or against the quoted price and/or as specified, ATNS must be given immediate written notice to this effect. ATNS reserves the right to implement remedies as provided for in the GCC.

### **3.12. WARRANTIES**

The bidder warrants that it can conclude this Agreement to the satisfaction of ATNS.

### **3.13. PARTIES NOT AFFECTED BY WAIVER OR BREACHES**

The waiver (whether express or implied) by any Party of any breach of the terms or conditions of this contract by the other Party shall not prejudice any remedy of the waiving party in respect of any continuing or other breach of the terms and conditions hereof.

No favour, delay, relaxation or indulgence on the part of any Party in exercising any power or right conferred on such Party in terms of this contract shall operate as a

waiver of such power or right nor shall any single or partial exercise of any such power or right under this agreement.

### **3.14. RETENTION**

On termination of this agreement, the bidder shall, on demand hand over all documentation provided as part of the project and all deliverables, etc., without the right of retention, to ATNS.

No agreement to amend or vary a contract or order or the conditions, stipulations or provisions thereof shall be valid and of any force and effect unless such agreement to amend or vary is entered into in writing and signed by the contracting parties. Any waiver of the requirement that the agreement to amend or vary shall be in writing, shall also be in writing.

### **3.15. CENTRAL SUPPLIER DATABASE**

It is a requirement that all suppliers/ services providers to ATNS shall be registered on the National Treasury Central Supplier Database (CSD).

Bidders are therefore required to register as a supplier on the CSD before submitting a bid. The CSD website can be accessed on the following link: <http://ocpo.treasury.gov.za/Pages/default.aspx>

Bidders are therefore required to submit proof of their registration on the CSD, or if not yet registered, provide proof of their application to be registered, with their bid.

No bid will be awarded, and a contract concluded with a bidder who is not registered on the CSD.

### **3.16. FORMAT OF BIDS**

Bidders must complete all the necessary bid documents and undertakings required in this bid document. Bidders are advised that their proposal should be concise, written in plain English and simply presented.

If applicable, Bidders are to set out their proposal in the format prescribed hereunder. This means that the proposal must be structured in the parts noted below. Information not submitted in the relevant part, may not be considered for evaluation purposes.

### **3.17. SARS TAX CLEARANCE CERTIFICATE(S)**

Bidder must ensure compliance with their tax obligations.

Bidders are required to submit their unique personal identification number (PIN) issued by SARS to enable the organ of state to view the taxpayer's profile and tax status.

Application for tax compliance status (TCS) or PIN may also be made via e-filing. To use this provision, taxpayers will need to register with SARS as e-filers through the website [www.sars.gov.za](http://www.sars.gov.za).

Bidders may also submit a printed TCS together with the bid.

In bids where consortia/ joint ventures/ sub-contractors are involved; each party must submit a separate proof of TCS/ PIN/ CSD number.

Where no TCS is available, but the bidder is registered on the Central Supplier Database (CSD), a CSD number must be provided.

Bids submitted without any one of the above, will be deemed to be non-responsive.

### **3.18. DECLARATION OF INTEREST**

Each party to the bid must complete and return the “Declaration of Interest”.

Bids submitted without a complete and signed Declaration of Interest will be deemed to be non-responsive.

### **3.19. INVITATION TO BID**

Bidders must complete, sign and return the full “Invitation to Bid” document.

Bids submitted without a completed and signed Invitation to Bid will be deemed to be non-responsive.

### **3.20. PRICING SCHEDULE**

Any budget amount that may be indicated in this document shall be deemed to be a guide only and Bidders are expected to submit a costing that is fair and reasonable.

All costs related to this assignment are to be allowed for in the pricing schedule and in the formats prescribed and must be returned as part of the submission. Bids submitted without a price or with an incomplete price, will be deemed to be non-responsive.

A pricing schedule with one of the specified elements (fees and reimbursable costs) omitted from the costing, may be considered non-responsive.

### **3.21. REGISTRATION ON THE CSD**

In this part, bidders must submit proof of their registration, or proof that they have applied for registration on the Central Supplier Database. Bids submitted without the required proof, will be deemed to be non-responsive.

### **3.22. REGISTRATION CERTIFICATES AND ACCREDITATION WITH OEMs or PROFESSIONAL BODDIES**

Registration with professional bodies. Bids submitted without proof will be deemed to be non-responsive.

**4. SECTION D: STANDARD BIDDING DOCUMENTS**

**SBD1: INVITATION TO BID**

**PART A**

<b>YOU ARE HEREBY INVITED TO BID FOR REQUIREMENTS OF THE AIR TRAFFIC AND NAVIGATION SERVICES SOC LIMITED (ATNS)</b>				
BID NUMBER:		CLOSING DATE:		CLOSING TIME:
DESCRIPTION				
<b>BID RESPONSE DOCUMENTS MAY BE DEPOSITED IN THE BID BOX SITUATED AT 07 WESSEL ST, RIVONIA, SANDTON, 2128</b>				
<b>BIDDING PROCEDURE ENQUIRIES MAY BE DIRECTED TO</b>			<b>TECHNICAL ENQUIRIES MAY BE DIRECTED TO:</b>	
CONTACT PERSON			CONTACT PERSON	
TELEPHONE NUMBER			TELEPHONE NUMBER	
FACSIMILE NUMBER			FACSIMILE NUMBER	
E-MAIL ADDRESS			E-MAIL ADDRESS	
<b>SUPPLIER INFORMATION</b>				
NAME OF BIDDER				
POSTAL ADDRESS				
STREET ADDRESS				
TELEPHONE NUMBER	CODE		NUMBER	
CELLPHONE NUMBER				
FACSIMILE NUMBER	CODE		NUMBER	
E-MAIL ADDRESS				
VAT REGISTRATION NUMBER				



SUPPLIER COMPLIANCE STATUS	TAX COMPLIANCE SYSTEM PIN:		OR	CENTRAL SUPPLIER DATABASE No:	MAAA
B-BBEE STATUS LEVEL VERIFICATION CERTIFICATE	TICK APPLICABLE BOX]  <input type="checkbox"/> Yes <input type="checkbox"/> No	B-BBEE STATUS LEVEL SWORN AFFIDAVIT	[TICK APPLICABLE BOX]  <input type="checkbox"/> Yes <input type="checkbox"/> No		

**[A B-BBEE STATUS LEVEL VERIFICATION CERTIFICATE/ SWORN AFFIDAVIT (FOR EMES & QSEs) MUST BE SUBMITTED IN ORDER TO QUALIFY FOR PREFERENCE POINTS FOR B-BBEE]**

ARE YOU THE ACCREDITED REPRESENTATIVE IN SOUTH AFRICA FOR THE GOODS /SERVICES /WORKS OFFERED?	<input type="checkbox"/> Yes <input type="checkbox"/> No  [IF YES ENCLOSE PROOF]	ARE YOU A FOREIGN BASED SUPPLIER FOR THE GOODS /SERVICES /WORKS OFFERED?	<input type="checkbox"/> Yes <input type="checkbox"/> No  [IF YES, ANSWER THE QUESTIONNAIRE BELOW ]
---	--	--	---

**QUESTIONNAIRE TO BIDDING FOREIGN SUPPLIERS**

IS THE ENTITY A RESIDENT OF THE REPUBLIC OF SOUTH AFRICA (RSA)?  YES  NO

DOES THE ENTITY HAVE A BRANCH IN THE RSA?  YES  NO

DOES THE ENTITY HAVE A PERMANENT ESTABLISHMENT IN THE RSA?  YES  NO

DOES THE ENTITY HAVE ANY SOURCE OF INCOME IN THE RSA?  YES  NO

IS THE ENTITY LIABLE IN THE RSA FOR ANY FORM OF TAXATION?  YES  NO

**IF THE ANSWER IS “NO” TO ALL OF THE ABOVE, THEN IT IS NOT A REQUIREMENT TO REGISTER FOR A TAX COMPLIANCE STATUS SYSTEM PIN CODE FROM THE SOUTH AFRICAN REVENUE SERVICE (SARS) AND IF NOT REGISTER AS PER 2.3 BELOW.**



**PART B**  
**TERMS AND CONDITIONS FOR BIDDING**

**1. BID SUBMISSION:**

- 1.1. BIDS MUST BE DELIVERED BY THE STIPULATED TIME TO THE CORRECT ADDRESS. LATE BIDS WILL NOT BE ACCEPTED FOR CONSIDERATION.
- 1.2. **ALL BIDS MUST BE SUBMITTED ON THE OFFICIAL FORMS PROVIDED—(NOT TO BE RE-TYPED) OR IN THE MANNER PRESCRIBED IN THE BID DOCUMENT.**
- 1.3. THIS BID IS SUBJECT TO THE PREFERENTIAL PROCUREMENT POLICY FRAMEWORK ACT, 2000 AND THE PREFERENTIAL PROCUREMENT REGULATIONS, 2017, THE GENERAL CONDITIONS OF CONTRACT (GCC) AND, IF APPLICABLE, ANY OTHER SPECIAL CONDITIONS OF CONTRACT.
- 1.4. **THE SUCCESSFUL BIDDER WILL BE REQUIRED TO FILL IN AND SIGN A WRITTEN CONTRACT FORM (SBD7).**

**2. TAX COMPLIANCE REQUIREMENTS**

- 2.1 BIDDERS MUST ENSURE COMPLIANCE WITH THEIR TAX OBLIGATIONS.
- 2.2 BIDDERS ARE REQUIRED TO SUBMIT THEIR UNIQUE PERSONAL IDENTIFICATION NUMBER (PIN) ISSUED BY SARS TO ENABLE THE ORGAN OF STATE TO VERIFY THE TAXPAYER'S PROFILE AND TAX STATUS.
- 2.3 APPLICATION FOR TAX COMPLIANCE STATUS (TCS) PIN MAY BE MADE VIA E-FILING THROUGH THE SARS WEBSITE [WWW.SARS.GOV.ZA](http://WWW.SARS.GOV.ZA).
- 2.4 BIDDERS MAY ALSO SUBMIT A PRINTED TCS CERTIFICATE TOGETHER WITH THE BID.
- 2.5 IN BIDS WHERE CONSORTIA / JOINT VENTURES / SUB-CONTRACTORS ARE INVOLVED, EACH PARTY MUST SUBMIT A SEPARATE TCS CERTIFICATE / PIN / CSD NUMBER.
- 2.6 WHERE NO TCS PIN IS AVAILABLE BUT THE BIDDER IS REGISTERED ON THE CENTRAL SUPPLIER DATABASE (CSD), A CSD NUMBER MUST BE PROVIDED.
- 2.7 NO BIDS WILL BE CONSIDERED FROM PERSONS IN THE SERVICE OF THE STATE, COMPANIES WITH DIRECTORS WHO ARE PERSONS IN THE SERVICE OF THE STATE, OR CLOSE CORPORATIONS WITH MEMBERS PERSONS IN THE SERVICE OF THE STATE."

**NB: FAILURE TO PROVIDE / OR COMPLY WITH ANY OF THE ABOVE PARTICULARS MAY RENDER THE BID INVALID.**



SIGNATURE OF BIDDER:

.....

CAPACITY UNDER WHICH THIS BID IS SIGNED:

.....

(Proof of authority must be submitted e.g. company resolution)

DATE:

.....





**ATNS FORM D**

**(PRICING SCHEDULE MUST BE IN A SEPARATE ENVELOPE-VOLUME 1C)**

CLOSING TIME: ON

BID NO.

VALIDITY: **120 DAYS** NAME OF BIDDER: .....

.....

ITEM NO.	QUANTITY	DESCRIPTION	BID PRICE IN RSA CURRENCY
----------	----------	-------------	---------------------------

BID PRICE MUST EXCLUDE VALUE-ADDED TAX

1		Supply, delivery, installation (Volume 2)	R
		Total Bid Price	R
		Alternative Offers (Bidder to advise)	R

Manuf .....  
 acture .....  
 r, type .....  
 and  
 model

Country of manufacture .....

Is the offer strictly to specification? YES / NO

If not to specification, state deviations .....

.....



Contract period excluding guarantee period .....

Is the price quoted fixed? YES / NO

Is the delivery and installation period fixed? YES / NO

Are the supplies/services guaranteed as required in the Bid specification? YES / NO

If a guarantee is not specifically required in the Bid specification, are the Supplies/ services guaranteed? YES / NO

Are you the accredited agent for the manufacturers of the equipment offered? YES / NO

Where in the Republic of South Africa can a machine/equipment of the type offered by you be inspected under working conditions? .....

What are the names and addresses of the factories where the supplies will be manufactured? .....

What is the approximate value of spares carried in stock in the Republic of South Africa for the equipment offered? R.....

Furnish full particulars (separately if necessary) of the arrangements which can be made by you for the efficient servicing/maintenance of the supplies/services locally .....

In respect of supplies to be specially imported, indicate -

- |       |  |                           |
|-------|--|---------------------------|
| (i)   | Whether a special import permit is required?   | YES / NO                  |
| (ii)  | The name and address of the person or company to whom payment is to be made abroad   | <p>.....</p> <p>.....</p> |
| (iii) | The amount in foreign currency to be paid by you abroad.<br>(See <b>Volume 1B</b> , paragraph 2.16.15.1)   | <p>.....</p>              |
| (iv)  | What ruling rate of exchange (at date of Bid) was applied in the conversion of this amount to South African currency (See <b>Volume 1B</b> , paragraph 2.16.15.1 and what was the date when this rate applied) | <p>.....</p>              |

## 1 PROTECTION OF PERSONAL INFORMATION

- 1.1 The Service Provider shall ensure that its employees, representatives and officers, comply with the provisions of the Protection of Personal Information Act, 2013 (“**POPIA**”) and all other applicable data protection laws and, without limitation to the foregoing, shall ensure the security and confidentiality of all Personal Information processed by that Party is in accordance with POPIA and all other applicable data protection laws.
- 1.2 The Service Provider must only process personal information of the Company and third parties on behalf of the Company, with the Company’s knowledge or authorisation, treat such information which comes to their knowledge as confidential and must not disclose it unless required by law or in the course of the proper performance of the Service Provider’s duties. The Service Provider must comply with the responsible party’s obligations in clause section 19 of POPIA.
- 1.3 Where the Service Provider, its agents, subcontractors, officers, directors, shareholders, representatives, or employees has/have access to any Personal Information held by the Company for any reason in connection with this Agreement or is/are supplied with or otherwise provided with Personal Information by the Company or on behalf of the Company for any purpose, or are supplied with or otherwise provided with Personal Information relating to the Services, the Service Provider shall:
  - 1.3.1 process such Personal Information only for purposes of performing its/their obligations under this Agreement and shall not otherwise modify, amend or alter the contents of such Personal Information or disclose or permit the disclosure of such Personal Information to any third party, unless specifically authorised to do so by the Company or as required by law or any regulatory authority, and shall take all such steps as may be necessary to protect and safeguard such Personal Information;
  - 1.3.2 without prejudice to the generality of the foregoing, ensure that appropriate, reasonable technical and organisational measures shall be taken by it/them to prevent –

- 1.3.2.1 the unauthorised or unlawful processing of such Personal Information; and
  - 1.3.2.2 the accidental loss or destruction of, or damage to, such Personal Information; and
  - 1.3.2.3 promptly notify the Company when it becomes aware of any unauthorised, unlawful or dishonest conduct or activities, or any breach of the terms of this Agreement relating to Personal Information.
- 1.4 The Service Provider shall be liable for all claims, demands, actions, costs, expenses (including but not limited to reasonable legal costs and disbursements), fines, losses and damages arising from or incurred by reason of any wrongful processing of any Personal Information by the Service Provider (including its agents, subcontractors, officers, representatives or employees) for any breach of its obligations or warranties in terms of clause **Error! Reference source not found.**
- 1.5 Both Parties will comply with their obligations under POPIA in relation to personal information for which they are the responsible party.
- 1.6 The Service Provider must notify the Company immediately where there are reasonable grounds to believe that personal information has been accessed or acquired by any unauthorised person (Data Breach) and must assist the Company, at its own cost: a) with any investigation or notice to the Regulator or data subjects that the Company may make in relation to a Data Breach; and b) in responding to any directions by the Regulator to publicise the Data Breach, including assisting the Company to make public announcements if required.
- 1.7 The Service Provider indemnifies the Company against any civil or criminal action or administrative fine or other penalty or loss as a result of the Service Provider's breach of this clause.

## **1. POPIA CONSENT**

- 1.1 The Service Provider, by submitting its proposal/ quotation, consents to the use of his/her personal information contained therein and confirms that:



1.1.1 The information is voluntarily supplied, without undue influence from any party;  
and

1.1.2 The information is necessary for the purposes of the engagement with ATNS.

1.2 The tenderer acknowledges that he /she is aware of his/her right to:

1.2.1 Access the information at any reasonable time for the purposes of rectification thereof;

1.2.2 Object to the processing of the information; Lodge a complaint with the Information Regulator.



**SBD 3.1 - PRICING SCHEDULE – FIRM PRICES  
(PURCHASES)**

NOTE: ONLY FIRM PRICES WILL BE ACCEPTED. NON-FIRM PRICES (INCLUDING PRICES SUBJECT TO RATES OF EXCHANGE VARIATIONS) WILL NOT BE CONSIDERED IN CASES WHERE DIFFERENT DELIVERY POINTS INFLUENCE THE PRICING, A SEPARATE PRICING SCHEDULE MUST BE SUBMITTED FOR EACH DELIVERY POINT

Name of bidder.....	Bid number.....
Closing Time 11:00	Closing date.....

OFFER TO BE VALID FOR.....DAYS FROM THE CLOSING DATE OF BID.

ITEM	QUANTITY	DESCRIPTION	BID PRICE IN RSA CURRENCY
NO.			** (ALL APPLICABLE TAXES INCLUDED)

- Required by: .....

- At: .....

- Brand and model .....  
Country of origin .....

Does the offer comply with the specification(s)? \*YES/NO

- If not to specification, indicate deviation(s) .....  
Period required for delivery .....

\*Delivery: Firm/not firm

- Delivery basis .....

Note: All delivery costs must be included in the bid price, for delivery at the prescribed destination.

\*\* “all applicable taxes” includes value- added tax, pay as you earn, income tax, unemployment insurance fund contributions and skills development levies.

**SBD 4: BIDDER’S DISCLOSURE**

**1. PURPOSE OF THE FORM**

Any person (natural or juristic) may make an offer or offers in terms of this invitation to bid. In line with the principles of transparency, accountability, impartiality, and ethics as enshrined in the Constitution of the Republic of South Africa and further expressed in various pieces of legislation, it is required for the bidder to make this declaration in respect of the details required hereunder.

Where a person/s are listed in the Register for Tender Defaulters and / or the List of Restricted Suppliers, that person will automatically be disqualified from the bid process.

**2. Bidder’s declaration**

2.1. Is the bidder, or any of its directors / trustees / shareholders / members / partners or any person having a controlling interest<sup>1</sup> in the enterprise, employed by the state? **YES/NO**

2.1.1. If so, furnish particulars of the names, individual identity numbers, and, if applicable, state employee numbers of sole proprietor/ directors / trustees / shareholders / members/ partners or any person having a controlling interest in the enterprise, in table below.

Full Name	Identity Number	Name of State institution

<sup>1</sup> the power, by one person or a group of persons holding the majority of the equity of an enterprise, alternatively, the person/s having the deciding vote or power to influence or to direct the course and decisions of the enterprise.

Full Name	Identity Number	Name of State institution

2.2. Do you, or any person connected with the bidder, have a relationship with any person who is employed by the procuring institution? **YES/NO**

2.2.1. If so, furnish particulars:

.....  
 .....

2.3. Does the bidder or any of its directors / trustees / shareholders / members / partners or any person having a controlling interest in the enterprise have any interest in any other related enterprise whether or not they are bidding for this contract?

**YES/NO**

2.3.1 If so, furnish particulars:

.....  
 .....

**3. DECLARATION**

I, \_\_\_\_\_ the \_\_\_\_\_ undersigned, (name)..... in submitting the accompanying bid, do hereby make the following statements that I certify to be true and complete in every respect:

- 3.1. I have read and I understand the contents of this disclosure;
- 3.2. I understand that the accompanying bid will be disqualified if this disclosure is found not to be true and complete in every respect;
- 3.3. The bidder has arrived at the accompanying bid independently from, and without consultation, communication, agreement or arrangement with any competitor.

However, communication between partners in a joint venture or consortium<sup>2</sup> will not be construed as collusive bidding.

- 3.4. In addition, there have been no consultations, communications, agreements or arrangements with any competitor regarding the quality, quantity, specifications, prices, including methods, factors or formulas used to calculate prices, market allocation, the intention or decision to submit or not to submit the bid, bidding with the intention not to win the bid and conditions or delivery particulars of the products or services to which this bid invitation relates.
- 3.5. The terms of the accompanying bid have not been, and will not be, disclosed by the bidder, directly or indirectly, to any competitor, prior to the date and time of the official bid opening or of the awarding of the contract.
- 3.6. There have been no consultations, communications, agreements or arrangements made by the bidder with any official of the procuring institution in relation to this procurement process prior to and during the bidding process except to provide clarification on the bid submitted where so required by the institution; and the bidder was not involved in the drafting of the specifications or terms of reference for this bid.
- 3.7. I am aware that, in addition and without prejudice to any other remedy provided to combat any restrictive practices related to bids and contracts, bids that are suspicious will be reported to the Competition Commission for investigation and possible imposition of administrative penalties in terms of section 59 of the Competition Act No 89 of 1998 and or may be reported to the National Prosecuting Authority (NPA) for criminal investigation and or may be restricted from conducting business with the public sector for a period not exceeding ten (10) years in terms of the Prevention and Combating of Corrupt Activities Act No 12 of 2004 or any other applicable legislation.

I CERTIFY THAT THE INFORMATION FURNISHED IN PARAGRAPHS 1, 2 and 3

ABOVE IS CORRECT.

I ACCEPT THAT THE STATE MAY REJECT THE BID OR ACT AGAINST ME IN TERMS OF PARAGRAPH 6 OF PFMA SCM INSTRUCTION 03 OF 2021/22 ON PREVENTING AND COMBATING ABUSE IN THE SUPPLY CHAIN MANAGEMENT SYSTEM SHOULD THIS DECLARATION PROVE TO BE FALSE.

---

<sup>2</sup> Joint venture or Consortium means an association of persons for the purpose of combining their expertise, property, capital, efforts, skill and knowledge in an activity for the execution of a contract.



.....

Signature

.....

Date

.....

Position

.....

Name of bidder



**SBD 6.1: PREFERENCE POINTS CLAIM FORM IN TERMS OF THE PREFERENTIAL  
PROCUREMENT REGULATIONS 2022**

This preference form must form part of all tenders invited. It contains general information and serves as a claim form for preference points for specific goals.

**NB: BEFORE COMPLETING THIS FORM, TENDERERS MUST STUDY THE GENERAL CONDITIONS, DEFINITIONS AND DIRECTIVES APPLICABLE IN RESPECT OF THE TENDER AND PREFERENTIAL PROCUREMENT REGULATIONS, 2022**

**1. GENERAL CONDITIONS**

- 1.1 The following preference point systems are applicable to invitations to tender:
- the 80/20 system for requirements with a Rand value of up to R50 000 000 (all applicable taxes included); and
  - the 90/10 system for requirements with a Rand value above R50 000 000 (all applicable taxes included).

**1.2 To be completed by the organ of state**

- a) The applicable preference point system for this tender is the 90/10 preference point system.

**1.3 Points for this tender (even in the case of a tender for income-generating contracts) shall be awarded for:**

- (a) Price; and
- (b) Specific Goals.

**1.4 To be completed by the organ of state:**

The maximum points for this tender are allocated as follows:

	<b>POINTS</b>
<b>PRICE</b>	90
<b>SPECIFIC GOALS</b>	10
<b>Total points for Price and SPECIFIC GOALS</b>	<b>100</b>



- 1.5 Failure on the part of a tenderer to submit proof or documentation required in terms of this tender to claim points for specific goals with the tender, will be interpreted to mean that preference points for specific goals are not claimed.
- 1.6 The organ of state reserves the right to require of a tenderer, either before a tender is adjudicated or at any time subsequently, to substantiate any claim in regard to preferences, in any manner required by the organ of state.

## 2. DEFINITIONS

- (a) **“tender”** means a written offer in the form determined by an organ of state in response to an invitation to provide goods or services through price quotations, competitive tendering process or any other method envisaged in legislation;
- (b) **“price”** means an amount of money tendered for goods or services, and includes all applicable taxes less all unconditional discounts;
- (c) **“rand value”** means the total estimated value of a contract in Rand, calculated at the time of bid invitation, and includes all applicable taxes;
- (d) **“tender for income-generating contracts”** means a written offer in the form determined by an organ of state in response to an invitation for the origination of income-generating contracts through any method envisaged in legislation that will result in a legal agreement between the organ of state and a third party that produces revenue for the organ of state, and includes, but is not limited to, leasing and disposal of assets and concession contracts, excluding direct sales and disposal of assets through public auctions; and
- (e) **“the Act”** means the Preferential Procurement Policy Framework Act, 2000 (Act No. 5 of 2000).

## 3. FORMULAE FOR PROCUREMENT OF GOODS AND SERVICES

### 3.1. POINTS AWARDED FOR PRICE

#### 3.1.1 THE 80/20 OR 90/10 PREFERENCE POINT SYSTEMS

A maximum of 80 or 90 points is allocated for price on the following basis:

**80/20**

**or**

**90/10**

$$P_s = 80 \left( 1 - \frac{P_t - P_{min}}{P_{min}} \right) \quad \text{or} \quad P_s = 90 \left( 1 - \frac{P_t - P_{min}}{P_{min}} \right)$$

Where

$P_s$  = Points scored for price of tender under consideration

$P_t$  = Price of tender under consideration

$P_{min}$  = Price of lowest acceptable tender

### 3.2. FORMULAE FOR DISPOSAL OR LEASING OF STATE ASSETS AND INCOME GENERATING PROCUREMENT

#### 3.2.1. POINTS AWARDED FOR PRICE

A maximum of 80 or 90 points is allocated for price on the following basis:

$$P_s = 80 \left( 1 + \frac{P_t - P_{max}}{P_{max}} \right) \quad \text{or} \quad P_s = 90 \left( 1 + \frac{P_t - P_{max}}{P_{max}} \right)$$

Where

$P_s$  = Points scored for price of tender under consideration

$P_t$  = Price of tender under consideration

$P_{max}$  = Price of highest acceptable tender

### 4. POINTS AWARDED FOR SPECIFIC GOALS

4.1. In terms of Regulation 4(2); 5(2); 6(2) and 7(2) of the Preferential Procurement Regulations, preference points must be awarded for specific goals stated in the tender. For the purposes of this tender the tenderer will be allocated points based on the goals stated in table 1 below as may be supported by proof/ documentation stated in the conditions of this tender:

4.2. In cases where organs of state intend to use Regulation 3(2) of the Regulations, which states that, if it is unclear whether the 80/20 or 90/10 preference point system applies,

an organ of state must, in the tender documents, stipulate in the case of—

(a) an invitation for tender for income-generating contracts, that either the 80/20 or 90/10 preference point system will apply and that the highest acceptable tender will be used to determine the applicable preference point system; or

(b) any other invitation for tender, that either the 80/20 or 90/10 preference point system will apply and that the lowest acceptable tender will be used to determine the applicable preference point system,  
then the organ of state must indicate the points allocated for specific goals for both the 90/10 and 80/20 preference point system.

**Table 1: Specific goals for the tender and points claimed are indicated per the table below.**

**Note to tenderers: The tenderer must indicate how they claim points for each preference point system.)**

The specific goals allocated points in terms of this tender	Number of points allocated (90/10 system) (To be completed by the organ of state)	Number of points claimed (90/10 system) (To be completed by the tenderer)
51% Black Owned Suppliers (Section 2(1)(d)(i) of the PPPFA)	<b>10,00</b>	

**DECLARATION WITH REGARD TO COMPANY/FIRM**

4.3. Name of company/firm.....

4.4. Company registration number: .....

4.5. TYPE OF COMPANY/ FIRM

- Partnership/Joint Venture / Consortium
- One-person business/sole propriety
- Close corporation
- Public Company

- Personal Liability Company
- (Pty) Limited
- Non-Profit Company
- State Owned Company

[TICK APPLICABLE BOX]

4.6. I, the undersigned, who is duly authorised to do so on behalf of the company/firm, certify that the points claimed, based on the specific goals as advised in the tender, qualifies the company/ firm for the preference(s) shown and I acknowledge that:

- i) The information furnished is true and correct;
- ii) The preference points claimed are in accordance with the General Conditions as indicated in paragraph 1 of this form;
- iii) In the event of a contract being awarded as a result of points claimed as shown in paragraphs 1.4 and 4.2, the contractor may be required to furnish documentary proof to the satisfaction of the organ of state that the claims are correct;
- iv) If the specific goals have been claimed or obtained on a fraudulent basis or any of the conditions of contract have not been fulfilled, the organ of state may, in addition to any other remedy it may have –
  - (a) disqualify the person from the tendering process;
  - (b) recover costs, losses or damages it has incurred or suffered as a result of that person's conduct;
  - (c) cancel the contract and claim any damages which it has suffered as a result of having to make less favourable arrangements due to such cancellation;
  - (d) recommend that the tenderer or contractor, its shareholders and directors, or only the shareholders and directors who acted on a fraudulent basis, be restricted from obtaining business from any organ of state for a period not exceeding 10 years, after the *audi alteram partem* (hear the other side) rule has been applied; and
  - (e) forward the matter for criminal prosecution, if deemed necessary.



.....  
**SIGNATURE(S) OF TENDERER(S)**

**SURNAME AND NAME:** .....

**DATE:** .....

**ADDRESS:** .....  
.....  
.....  
.....



## GENERAL CONDITIONS OF CONTRACT

### TABLE OF CLAUSES

1. Definitions
2. Application
3. General
4. Standards
5. Use of contract documents and information; inspection
6. Patent rights
7. Performance security
8. Inspections, tests and analysis
9. Packing
10. Delivery and documents
11. Insurance
12. Transportation
13. Incidental services
14. Spare parts
15. Warranty
16. Payment
17. Prices
18. Contract amendments
19. Assignment
20. Subcontracts
21. Delays in the supplier's performance
22. Penalties
23. Termination for default
24. Dumping and countervailing duties
25. Force Majeure
26. Termination for insolvency
27. Settlement of disputes
28. Limitation of liability
29. Governing language
30. Applicable law
31. Notices



32. Taxes and duties
33. National Industrial Participation Programme (NIPP)
34. Prohibition of restrictive practices

## 1. Definitions

The following terms shall be interpreted as indicated:

- 1.1. "Closing time" means the date and hour specified in the bidding documents for the receipt of bids.
- 1.2. "Contract" means the written agreement entered into between the purchaser and the supplier, as recorded in the contract form signed by the parties, including all attachments and appendices thereto and all documents incorporated by reference therein.
- 1.3. "Contract price" means the price payable to the supplier under the contract for the full and proper performance of his contractual obligations.
- 1.4. "Corrupt practice" means the offering, giving, receiving, or soliciting of anything of value to influence the action of a public official in the procurement process or in contract execution.
- 1.5. "Countervailing duties" are imposed in cases where an enterprise abroad is subsidized by its government and encouraged to market its products internationally.
- 1.6. "Country of origin" means the place where the goods were mined, grown or produced or from which the services are supplied. Goods are produced when, through manufacturing, processing or substantial and major assembly of components, a commercially recognized new product results that is substantially different in basic characteristics or in purpose or utility from its components.
- 1.7. "Day" means calendar day.
- 1.8. "Delivery" means delivery in compliance of the conditions of the contract or order.
- 1.9. "Delivery ex stock" means immediate delivery directly from stock on hand.
- 1.10. "Delivery into consignees store or to his site" means delivered and unloaded in the specified store or depot or on the specified site in compliance with the conditions of the contract or order, the supplier bearing all risks and charges involved until the supplies are so delivered and a valid receipt is obtained.
- 1.11. "Dumping" occurs when a private enterprise abroad market its goods on own initiative in the RSA at lower prices than that of the country of origin and which have the potential to harm the local industries in the RSA.



- 1.12.** “Force majeure” means an event beyond the control of the supplier and not involving the supplier’s fault or negligence and not foreseeable. Such events may include, but is not restricted to, acts of the purchaser in its sovereign capacity, wars or revolutions, fires, floods, epidemics, quarantine restrictions and freight embargoes.
- 1.13.** “Fraudulent practice” means a misrepresentation of facts to influence a procurement process or the execution of a contract to the detriment of any bidder and includes collusive practice among bidders (prior to or after bid submission) designed to establish bid prices at artificial non-competitive levels and to deprive the bidder of the benefits of free and open competition.
- 1.14.** “GCC” means the General Conditions of Contract.
- 1.15.** “Goods” means all of the equipment, machinery, and/or other materials that the supplier is required to supply to the purchaser under the contract.
- 1.16.** “Imported content” means that portion of the bidding price represented by the cost of components, parts or materials which have been or are still to be imported (whether by the supplier or his subcontractors) and which costs are inclusive of the costs abroad, plus freight and other direct importation costs such as landing costs, dock dues, import duty, sales duty or other similar tax or duty at the South African place of entry as well as transportation and handling charges to the factory in the Republic where the supplies covered by the bid will be manufactured.
- 1.17.** “Local content” means that portion of the bidding price which is not included in the imported content provided that local manufacture does take place.
- 1.18.** “Manufacture” means the production of products in a factory using labour, materials, components, and machinery and includes other related value-adding activities.
- 1.19.** “Order” means an official written order issued for the supply of goods or works or the rendering of a service.
- 1.20.** “Project site,” where applicable, means the place indicated in bidding documents.
- 1.21.** “Purchaser” means the organization purchasing the goods.
- 1.22.** “Republic” means the Republic of South Africa.
- 1.23.** “SCC” means the Special Conditions of Contract.
- 1.24.** “Services” means those functional services ancillary to the supply of the goods, such as transportation and any other incidental services, such as installation, commissioning, provision of technical assistance, training, catering, gardening, security, maintenance and other such obligations of the supplier covered under the contract.
- 1.25.** “Written” or “in writing” means handwritten in ink or any form of electronic or mechanical writing.

## 2. Application

- 2.1. These general conditions are applicable to all bids, contracts and orders including bids for functional and professional services, sales, hiring, letting and the granting or acquiring of rights, but excluding immovable property, unless otherwise indicated in the bidding documents.
- 2.2. Where applicable, special conditions of contract are also laid down to cover specific supplies, services or works.
- 2.3. Where such special conditions of contract are in conflict with these general conditions, the special conditions shall apply.

## 3. General

- 3.1. Unless otherwise indicated in the bidding documents, the purchaser shall not be liable for any expense incurred in the preparation and submission of a bid. Where applicable a non-refundable fee for documents may be charged.
- 3.2. With certain exceptions, invitations to bid are only published in the Government Tender Bulletin. The Government Tender Bulletin may be obtained directly from the Government Printer, Private Bag X85, Pretoria 0001, or accessed electronically from [www.treasury.gov.za](http://www.treasury.gov.za).

## 4. Standards

- 4.1. The goods supplied shall conform to the standards mentioned in the bidding documents and specifications.

## 5. Use of contract documents and information; inspection.

- 5.1. The supplier shall not, without the purchaser's prior written consent, disclose the contract, or any provision thereof, or any specification, plan, drawing, pattern, sample, or information furnished by or on behalf of the purchaser in connection therewith, to any person other than a person employed by the supplier in the performance of the contract. Disclosure to any such employed person shall be made in confidence and shall extend only so far as may be necessary for purposes of such performance.
- 5.2. The supplier shall not, without the purchaser's prior written consent, make use of any document or information mentioned in GCC clause except for purposes of performing the contract.
- 5.3. Any document, other than the contract itself mentioned in GCC clause shall remain the property of the purchaser and shall be returned (all copies) to the purchaser on completion of the supplier's performance under the contract if so required by the purchaser.

5.4. The supplier shall permit the purchaser to inspect the supplier's records relating to the performance of the supplier and to have them audited by auditors appointed by the purchaser, if so, required by the purchaser.

## **6. Patent rights**

6.1. The supplier shall indemnify the purchaser against all third-party claims of infringement of patent, trademark, or industrial design rights arising from use of the goods or any part thereof by the purchaser.

## **7. Performance security**

7.1. Within thirty (30) days of receipt of the notification of contract award, the successful bidder shall furnish to the purchaser the performance security of the amount specified in SCC.

7.2. The proceeds of the performance security shall be payable to the purchaser as compensation for any loss resulting from the supplier's failure to complete his obligations under the contract.

7.3. The performance security shall be denominated in the currency of the contract, or in a freely convertible currency acceptable to the purchaser and shall be in one of the following forms:

(a) a bank guarantee or an irrevocable letter of credit issued by a reputable bank located in the purchaser's country or abroad, acceptable to the purchaser, in the form provided in the bidding documents or another form acceptable to the purchaser; or a cashier's or certified cheque

7.4. The performance security will be discharged by the purchaser and returned to the supplier not later than thirty (30) days following the date of completion of the supplier's performance obligations under the contract, including any warranty obligations, unless otherwise specified in SCC.

## **8. Inspections, tests and analyses**

8.1. All pre-bidding testing will be for the account of the bidder.

8.2. If it is a bid condition that supplies to be produced or services to be rendered should at any stage during production or execution or on completion be subject to inspection, the premises of the bidder or contractor shall be open, at all reasonable hours, for inspection by a representative of the Department or an organization acting on behalf of the Department.

8.3. If there are no inspection requirements indicated in the bidding documents and no mention is made in the contract, but during the contract period it is decided that

inspections shall be carried out, the purchaser shall itself make the necessary arrangements, including payment arrangements with the testing authority concerned.

- 8.4. If the inspections, tests and analyses referred to in clauses 8.2 and 8.3 show the supplies to be in accordance with the contract requirements, the cost of the inspections, tests and analyses shall be defrayed by the purchaser.
- 8.5. Where the supplies or services referred to in clauses 8.2 and 8.3 do not comply with the contract requirements, irrespective of whether such supplies or services are accepted or not, the cost in connection with these inspections, tests or analyses shall be defrayed by the supplier.
- 8.6. Supplies and services which are referred to in clauses 8.2 and 8.3 and which do not comply with the contract requirements may be rejected.
- 8.7. Any contract supplies may on or after delivery be inspected, tested or analysed and may be rejected if found not to comply with the requirements of the contract. Such rejected supplies shall be held at the cost and risk of the supplier who shall, when called upon, remove them immediately at his own cost and forthwith substitute them with supplies which do comply with the requirements of the contract. Failing such removal, the rejected supplies shall be returned at the suppliers cost and risk. Should the supplier fail to provide the substitute supplies forthwith, the purchaser may, without giving the supplier further opportunity to substitute the rejected supplies, purchase such supplies as may be necessary at the expense of the supplier.
- 8.8. The provisions of clauses 8.4 to 8.7 shall not prejudice the right of the purchaser to cancel the contract on account of a breach of the conditions thereof, or to act in terms of Clause 23 of GCC.

## **9. Packing**

- 9.1. The supplier shall provide such packing of the goods as is required to prevent their damage or deterioration during transit to their final destination, as indicated in the contract. The packing shall be sufficient to withstand, without limitation, rough handling during transit and exposure to extreme temperatures, salt and precipitation during transit, and open storage. Packing, case size and weights shall take into consideration, where appropriate, the remoteness of the goods' final destination and the absence of heavy handling facilities at all points in transit.
- 9.2. The packing, marking, and documentation within and outside the packages shall comply strictly with such special requirements as shall be expressly provided for in the contract, including additional requirements, if any, specified in SCC, and in any subsequent instructions ordered by the purchaser.

## **10. Delivery and documents**

10.1. Delivery of the goods shall be made by the supplier in accordance with the terms specified in the contract. The details of shipping and/or other documents to be furnished by the supplier are specified in SCC.

10.2. Documents to be submitted by the supplier are specified in SCC.

## **11. Insurance**

11.1. The goods supplied under the contract shall be fully insured in a freely convertible currency against loss or damage incidental to manufacture or acquisition, transportation, storage and delivery in the manner specified in the SCC.

## **12. Transportation**

12.1. Should a price other than an all-inclusive delivered price be required, this shall be specified in the SCC.

## **13. Incidental services**

13.1. The supplier may be required to provide any or all of the following services, including additional services, if any, specified in SCC:

- a. performance or supervision of on-site assembly and/or commissioning of the supplied goods;
- b. furnishing of tools required for assembly and/or maintenance of the supplied goods;
- c. furnishing of a detailed operations and maintenance manual for each appropriate unit of the supplied goods;
- d. performance or supervision or maintenance and/or repair of the supplied goods, for a period of time agreed by the parties, provided that this service shall not relieve the supplier of any warranty obligations under this contract; and
- e. training of the purchaser's personnel, at the supplier's plant and/or on-site, in assembly, start-up, operation, maintenance, and/or repair of the supplied goods.

13.2. Prices charged by the supplier for incidental services, if not included in the contract price for the goods, shall be agreed upon in advance by the parties and shall not exceed the prevailing rates charged to other parties by the supplier for similar services.

## **14. Spare parts**

14.1. As specified in SCC, the supplier may be required to provide any or all of the following materials, notifications, and information pertaining to spare parts manufactured or distributed by the supplier:

- (a) such spare parts as the purchaser may elect to purchase from the supplier, provided that this election shall not relieve the supplier of any warranty obligations under the contract; and
- (b) in the event of termination of production of the spare parts:
  - i) Advance notification to the purchaser of the pending termination, in sufficient time to permit the purchaser to procure needed requirements; and
  - ii) following such termination, furnishing at no cost to the purchaser, the blueprints, drawings, and specifications of the spare parts, if requested.

## 15. Warranty

15.1. The supplier warrants that the goods supplied under the contract are new, unused, of the most recent or current models, and that they incorporate all recent improvements in design and materials unless provided otherwise in the contract. The supplier further warrants that all goods supplied under this contract shall have no defect, arising from design, materials, or workmanship (except when the design and/or material is required by the purchaser's specifications) or from any act or omission of the supplier, that may develop under normal use of the supplied goods in the conditions prevailing in the country of final destination.

15.2. This warranty shall remain valid for twelve (12) months after the goods, or any portion thereof as the case may be, have been delivered to and accepted at the final destination indicated in the contract, or for eighteen (18) months after the date of shipment from the port or place of loading in the source country, whichever period concludes earlier, unless specified otherwise in SCC.

15.3. The purchaser shall promptly notify the supplier in writing of any claims arising under this warranty.

15.4. Upon receipt of such notice, the supplier shall, within the period specified in SCC and with all reasonable speed, repair or replace the defective goods or parts thereof, without costs to the purchaser.

15.5. If the supplier, having been notified, fails to remedy the defect(s) within the period specified in SCC, the purchaser may proceed to take such remedial action as may be necessary, at the supplier's risk and expense and without prejudice to any other rights which the purchaser may have against the supplier under the contract.

## 16. Payment



- 16.1. The method and conditions of payment to be made to the supplier under this contract shall be specified in SCC.
- 16.2. The supplier shall furnish the purchaser with an invoice accompanied by a copy of the delivery note and upon fulfilment of other obligations stipulated in the contract.
- 16.3. Payments shall be made promptly by the purchaser, but in no case later than thirty (30) days after submission of an invoice or claim by the supplier.
- 16.4. Payment will be made in Rand unless otherwise stipulated in SCC.

## 17. Prices

- 17.1. Prices charged by the supplier for goods delivered and services performed under the contract shall not vary from the prices quoted by the supplier in his bid, with the exception of any price adjustments authorized in SCC or in the purchaser's request for bid validity extension, as the case may be.

## 18. Contract amendments

- 18.1. No variation in or modification of the terms of the contract shall be made except by written amendment signed by the parties concerned.

## 19. Assignment

- 19.1. The supplier shall not assign, in whole or in part, its obligations to perform under the contract, except with the purchaser's prior written consent.

## 20. Subcontracts

- 20.1. The supplier shall notify the purchaser in writing of all subcontracts awarded under this contract if not already specified in the bid. Such notification, in the original bid or later, shall not relieve the supplier from any liability or obligation under the contract.

## 21. Delays in the supplier's performance

- 21.1. Delivery of the goods and performance of services shall be made by the supplier in accordance with the time schedule prescribed by the purchaser in the contract.
- 21.2. If at any time during performance of the contract, the supplier or its subcontractor(s) should encounter conditions impeding timely delivery of the goods and performance of services, the supplier shall promptly notify the purchaser in writing of the fact of the delay, its likely duration and its cause(s). As soon as practicable after receipt of the supplier's notice, the purchaser shall evaluate the situation and may at his discretion

extend the supplier's time for performance, with or without the imposition of penalties, in which case the extension shall be ratified by the parties by amendment of contract.

- 21.3. No provision in a contract shall be deemed to prohibit the obtaining of supplies or services from a national department, provincial department, or a local authority.
- 21.4. The right is reserved to procure outside of the contract small quantities or to have minor essential services executed if an emergency arises, the supplier's point of supply is not situated at or near the place where the supplies are required, or the supplier's services are not readily available.
- 21.5. Except as provided under GCC Clause 25, a delay by the supplier in the performance of its delivery obligations shall render the supplier liable to the imposition of penalties, pursuant to GCC Clause 22, unless an extension of time is agreed upon pursuant to GCC Clause without the application of penalties.
- 21.6. Upon any delay beyond the delivery period in the case of a supplies contract, the purchaser shall, without cancelling the contract, be entitled to purchase supplies of a similar quality and up to the same quantity in substitution of the goods not supplied in conformity with the contract and to return any goods delivered later at the supplier's expense and risk, or to cancel the contract and buy such goods as may be required to complete the contract and without prejudice to his other rights, be entitled to claim damages from the supplier.

## **22. Penalties**

- 22.1. Subject to GCC Clause 25, if the supplier fails to deliver any or all of the goods or to perform the services within the period(s) specified in the contract, the purchaser shall, without prejudice to its other remedies under the contract, deduct from the contract price, as a penalty, a sum calculated on the delivered price of the delayed goods or unperformed services using the current prime interest rate calculated for each day of the delay until actual delivery or performance. The purchaser may also consider termination of the contract pursuant to GCC Clause 23.

## **23. Termination for default**

- 23.1. The purchaser, without prejudice to any other remedy for breach of contract, by written notice of default sent to the supplier, may terminate this contract in whole or in part:
- (a) if the supplier fails to deliver any or all of the goods within the period(s) specified in the contract, or within any extension thereof granted by the purchaser pursuant to GCC Clause 21.2.
  - (b) if the Supplier fails to perform any other obligation(s) under the contract; or



- (c) if the supplier, in the judgment of the purchaser, has engaged in corrupt or fraudulent practices in competing for or in executing the contract.
- 23.2. In the event the purchaser terminates the contract in whole or in part, the purchaser may procure, upon such terms and in such manner as it deems appropriate, goods, works or services similar to those undelivered, and the supplier shall be liable to the purchaser for any excess costs for such similar goods, works or services. However, the supplier shall continue performance of the contract to the extent not terminated.
- 23.3. Where the purchaser terminates the contract in whole or in part, the purchaser may decide to impose a restriction penalty on the supplier by prohibiting such supplier from doing business with the public sector for a period not exceeding 10 years.
- 23.4. If a purchaser intends imposing a restriction on a supplier or any person associated with the supplier, the supplier will be allowed a time period of not more than fourteen (14) days to provide reasons why the envisaged restriction should not be imposed. Should the supplier fail to respond within the stipulated fourteen (14) days the purchaser may regard the intended penalty as not objected against and may impose it on the supplier.
- 23.5. Any restriction imposed on any person by the Accounting Officer / Authority will, at the discretion of the Accounting Officer / Authority, also be applicable to any other enterprise or any partner, manager, director or other person who wholly or partly exercises or exercised or may exercise control over the enterprise of the first-mentioned person, and with which enterprise or person the first-mentioned person, is or was in the opinion of the Accounting Officer / Authority actively associated.
- 23.6. If a restriction is imposed, the purchaser must, within five (5) working days of such imposition, furnish the National Treasury, with the following information:
- i) the name and address of the supplier and / or person restricted by the purchaser;
  - ii) the date of commencement of the restriction
  - iii) the period of restriction; and
  - iv) the reasons for the restriction.

These details will be loaded in the National Treasury's central database of suppliers or persons prohibited from doing business with the public sector.

- 23.7. If a court of law convicts a person of an offence as contemplated in sections 12 or 13 of the Prevention and Combating of Corrupt Activities Act, No. 12 of 2004, the court may also rule that such person's name be endorsed on the Register for Tender Defaulters. When a person's name has been endorsed on the Register, the person will be prohibited from doing business with the public sector for a period not less than five years and not

more than 10 years. The National Treasury is empowered to determine the period of restriction and each case will be dealt with on its own merits. According to section 32 of the Act the Register must be open to the public. The Register can be perused on the National Treasury website.

**24. Anti-dumping and countervailing duties and rights**

24.1. When, after the date of bid, provisional payments are required, or anti-dumping or countervailing duties are imposed, or the amount of a provisional payment or anti-dumping or countervailing right is increased in respect of any dumped or subsidized import, the State is not liable for any amount so required or imposed, or for the amount of any such increase. When, after the said date, such a provisional payment is no longer required or any such anti-dumping or countervailing right is abolished, or where the amount of such provisional payment or any such right is reduced, any such favourable difference shall on demand be paid forthwith by the contractor to the State or the State may deduct such amounts from moneys (if any) which may otherwise be due to the contractor in regard to supplies or services which he delivered or rendered, or is to deliver or render in terms of the contract or any other contract or any other amount which may be due to him



**25. Force Majeure**

25.1. Notwithstanding the provisions of GCC Clauses 22 and 23, the supplier shall not be liable for forfeiture of its performance security, damages, or termination for default if and to the extent that his delay in performance or other failure to perform his obligations under the contract is the result of an event of force majeure.

25.2. If a force majeure situation arises, the supplier shall promptly notify the purchaser in writing of such condition and the cause thereof. Unless otherwise directed by the purchaser in writing, the supplier shall continue to perform its obligations under the contract as far as is reasonably practical and shall seek all reasonable alternative means for performance not prevented by the force majeure event.

**26. Termination for insolvency**

26.1. The purchaser may at any time terminate the contract by giving written notice to the supplier if the supplier becomes bankrupt or otherwise insolvent. In this event, termination will be without compensation to the supplier, provided that such termination will not

prejudice or affect any right of action or remedy which has accrued or will accrue thereafter to the purchaser.

## **27. Settlement of Disputes**

27.1. If any dispute or difference of any kind whatsoever arises between the purchaser and the supplier in connection with or arising out of the contract, the parties shall make every effort to resolve amicably such dispute or difference by mutual consultation.

27.2. If, after thirty (30) days, the parties have failed to resolve their dispute or difference by such mutual consultation, then either the purchaser or the supplier may give notice to the other party of his intention to commence with mediation. No mediation in respect of this matter may be commenced unless such notice is given to the other party.

27.3. Should it not be possible to settle a dispute by means of mediation, it may be settled in a South African court of law.

27.4. Mediation proceedings shall be conducted in accordance with the rules of procedure specified in the SCC.

27.5. Notwithstanding any reference to mediation and/or court proceedings herein,

(a) the parties shall continue to perform their respective obligations under the contract unless they otherwise agree; and

(b) the purchaser shall pay the supplier any monies due the supplier.

## **28. Limited liability**

28.1. Except in cases of criminal negligence or wilful misconduct, and in the case of infringement pursuant to Clause 6;

a) the supplier shall not be liable to the purchaser, whether in contract, tort, or otherwise, for any indirect or consequential loss or damage, loss of use, loss of production, or loss of profits or interest costs, provided that this exclusion shall not apply to any obligation of the supplier to pay penalties and/or damages to the purchaser; and

b) the aggregate liability of the supplier to the purchaser, whether under the contract, in tort or otherwise, shall not exceed the total contract price, provided that this limitation shall not apply to the cost of repairing or replacing defective equipment.

## **29. Language**

29.1. The contract shall be written in English. All correspondence and other documents pertaining to the contract that is exchanged by the parties shall also be written in English.

### **30. Applicable law**

30.1. The contract shall be interpreted in accordance with South African laws, unless otherwise specified in SCC.

### **31. Notices**

31.1. Every written acceptance of a bid shall be posted to the supplier concerned by registered or certified mail and any other notice to him shall be posted by ordinary mail to the address furnished in his bid or to the address notified later by him in writing and such posting shall be deemed to be proper service of such notice

31.2. The time mentioned in the contract documents for performing any act after such aforesaid notice has been given, shall be reckoned from the date of posting of such notice.

### **32. Taxes and duties**

32.1. A foreign supplier shall be entirely responsible for all taxes, stamp duties, license fees, and other such levies imposed outside the purchaser's country.

32.2. A local supplier shall be entirely responsible for all taxes, duties, license fees, etc., incurred until delivery of the contracted goods to the purchaser.

32.3. No contract shall be concluded with any bidder whose tax matters are not in order. Prior to the award of a bid the Department must be in possession of a tax clearance certificate, submitted by the bidder. This certificate must be an original issued by the South African Revenue Services.

### **33. National Industrial Participation (NIP) Programme**

33.1. The NIP Programme administered by the Department of Trade and Industry shall be applicable to all contracts that are subject to the NIP obligation.

### **34. Prohibition of Restrictive practices**

34.1. In terms of section 4 (1) (b) (iii) of the Competition Act No. 89 of 1998, as amended, an agreement between, or concerted practice by, firms, or a decision by an association of firms, is prohibited if it is between parties in a horizontal relationship and if a bidder (s) is / are or a contractor(s) was / were involved in collusive bidding (or bid rigging).

34.2. If a bidder(s) or contractor(s), based on reasonable grounds or evidence obtained by the purchaser, has / have engaged in the restrictive practice referred to above, the purchaser may refer the matter to the Competition Commission for investigation and



possible imposition of administrative penalties as contemplated in the Competition Act No. 89 of 1998.

- 34.3. If a bidder(s) or contractor(s), has / have been found guilty by the Competition Commission of the restrictive practice referred to above, the purchaser may, in addition and without prejudice to any other remedy provided for, invalidate the bid(s) for such item(s) offered, and / or terminate the contract in whole or part, and / or restrict the bidder(s) or contractor(s) from conducting business with the public sector for a period not exceeding ten (10) years and / or claim damages from the bidder(s) or contractor(s) concerned.

